

# MOTOR VEHICLE DIMENSIONS—SAE J1100 JUN84

## SAE Recommended Practice

Report of the Human Factors Engineering Committee, approved September 1973, last revised June 1984.

1. *Scope*—This SAE Recommended Practice defines a uniform set of interior and exterior dimensions for passenger cars, multipurpose passenger vehicles, and trucks.

2. *General*—The dimensions in this report will enable the measurement of a vehicle as designed. The prefix "A" may precede a dimension taken from a vehicle as built, which will enable a comparison between vehicles as designed and/or built.

This recommended practice supersedes the dimension definitions in J1100—Passenger Car Dimensions, previously contained in Section E-1, and Truck Dimensions previously contained in E-7 of the SAE Drawing Standards.

All dimensions are defined normal to the three-dimensional reference system, described in SAE J182a, "Motor Vehicle Fiducial Marks," except for ground-related dimensions which are defined normal to ground with the vehicle loaded to a design load weight, unless otherwise defined in the dimension definition. All dimensions are measured to the base vehicle and do not include Regular Production Options (RPO) or accessory parts, unless otherwise specified by the dimension definition.

The dimensions in this standard are classified in groups of relevant interest. Each dimension is assigned a code which is composed of a prefix letter denoting the direction or type of dimension and a number issued

in sequence as required by each prefix letter. The code is interpreted as follows:

The prefix letter:

W—Width dimensions  
H—Height dimensions  
PD—Passenger distribution dimensions  
L—Length dimensions  
S—Surface area dimensions  
SD—Seat facing direction dimensions  
V—Volume dimensions

The number:

1-99 Interior dimensions  
100-199 Exterior dimensions  
200-299 Cargo or luggage dimensions  
300-399 Interior dimensions—Unique for Truck and MPV's  
400-499 Exterior dimensions—Unique for Truck and MPV's  
500-599 Cargo Dimensions—Unique for Truck and MPV's

To assist in locating dimensions in this report, numerical and alphabetic sequences are shown in Tables 2 thru 9.

34.98

**2.1 Interior Dimensions**—All interior dimensions are defined with an adjustable front seat in its rearmost normal driving position, resulting in the design H-point being positioned at the seating reference point (SgRP) position. All other adjustable features, such as an adjustable steering wheel, and adjustable seat height, a seatback that adjusts independently from the seat cushion, power 4-way or 6-way seats, etc., shall be positioned in their normal driving position as specified by the manufacturer. Steering wheel shall be positioned with front wheels in straight ahead position.

All interior dimensions are defined on the Y-plane of the driver, unless otherwise defined in the dimensions definition. The H-point machine  $\phi$  and two-dimensional drafting template specified in SAE J826 APR80, "Devices for Use in Defining and Measuring Vehicle Seating Accommodation," shall use the 95th percentile leg segments.

$\phi$  For heavy duty trucks, suspension seats will be positioned as specified by the vehicle manufacturer in the normal driving position with any fore and aft isolator locked out.

**2.2 Exterior Dimensions**—All exterior dimensions terminate at the outside surface of sheet metal, bumpers, or integral moldings, unless otherwise specified. The front wheels shall be positioned in the straight-ahead position. All exterior dimensions define the proportional shape of the vehicle, as opposed to its designed pieces. For example, when two vehicles with the same front end profile are designed, one with a bolt on bumper and one with the bumper integrated with the front end, the front end length dimension (L126) on both vehicles will be the same.

**2.3 Cargo Dimensions**—All dimensions are measured with the front seat positioned the same as for interior dimensions and all rear seats folded as specified by the manufacturer. All head restraints shall be in the stowed position and considered part of the seat.

**2.4 Luggage Capacity**—The luggage capacity will be measured with the use of simulated luggage described in paragraph 8.1 and properly installed, detailed in paragraph 8.2, in a luggage compartment separate from the passenger compartment.

### 3. Definitions of Terms

#### 3.1 Motor Vehicles

**3.1.1 PASSENGER CAR**—A vehicle with motive power, except a multipurpose passenger vehicle, motorcycle, or trailer, designed for carrying 10 persons or less.

**3.1.1.1 Station Wagon**—A passenger car with an extended upper to increase the cargo and/or passenger capacity.

**3.1.1.2 Hatchback**—A passenger car with the rear access door encompassing the back light.

**3.1.2 MULTIPURPOSE PASSENGER VEHICLE (MPV)**—A vehicle with motive power, except a trailer, designed to carry 10 persons or less, which is constructed either on a truck chassis or with special features for occasional off-road operation.

**3.1.3 TRUCK**—A vehicle with motive power, except a trailer, designed primarily for the transportation of property or special-purpose equipment.

**3.1.3.1—Light Truck** is the classification of a self-propelled vehicle which is designed primarily to transport property or special purpose equipment, and has a maximum gross vehicle weight rating (GVWR) of 10 000 lb (4536 kg) or less.

GVWR is the value specified by the vehicle manufacturer as the loaded weight of a single vehicle.

**3.1.3.2—Heavy Truck** is the classification of a self-propelled vehicle which is designed primarily to transport property or special purpose equipment, and has a gross vehicle weight rating over 10 000 lb (4536 kg).

**3.2 Vehicle Weights**—Specific vehicle weights with the addition of specified loads are defined below. These vehicle weights are established to enable uniform static comparisons of dimensions affected by the ground plane and vehicle pitch (attitude).

**3.2.1 CURB WEIGHT**—The weight of a motor vehicle with standard equipment only; maximum capacity of engine fuel, oil, and coolant. For heavy trucks, the weight does not include engine fuel.

**3.2.2 DESIGN LOAD WEIGHT—PASSENGER CAR**—Curb weight, plus passengers and luggage or cargo load as specified by manufacturer, each passenger weighing 150 lb (68 kg).

**3.2.3 DESIGN LOAD WEIGHT/HEIGHT—TRUCKS AND MPV'S**—The height of a motor vehicle with the front and rear suspension at the manufacturer's design-loaded condition and the front and rear springs loaded to their rated capacity.

**3.3 Three-Dimensional Reference System**—The relationship of three orthogonal planes established by the manufacturers in the initial design stages of the vehicle and which remain permanent. The planes are used to determine dimensional relationships within the vehicle [Fig. 1 of SAE J182a (September, 1973)] and are defined below:

**3.3.1 ZERO "X" PLANE**—(Vertical body zero plane) is a plane normal  $\phi$  to the "Y" plane.

**3.3.2 ZERO "Y" PLANE**—(Centerline body zero plane) is a vertical plane  $\phi$  which passes through the longitudinal centerline of the vehicle.

**3.3.3 ZERO "Z" PLANE**—(Horizontal body zero plane) is a plane normal to the "X" and "Y" planes.

**3.3.4 NEGATIVE COORDINATE**—The negative direction is forward of the zero "X" plane, left of the zero "Y" plane, and below the zero "Z" plane.

**3.3.5 COORDINATE DIMENSION**—All points of interest are described as coordinate dimensioned from the intersection of the zero planes in the three-dimensional reference system. X, Y, Z coordinates are dimensioned to their respective planes.

**3.4 Vehicle Fiducial Marks** [See SAE J182a (September, 1973)]—These are holes, surfaces, marks, or indentations on the vehicle body as described by the manufacturer. Their location is specified in the three-dimensional reference system by X, Y, Z coordinates and to ground with the vehicle at a specified vehicle weight.

**3.5 Eyellipse**—See SAE J941 MAR81, "Motor Vehicle Driver's Eye  $\phi$  Range."

**3.6 Two- and Three-Dimensional Devices**—See SAE J826 APR80.  $\phi$

**3.7 Head Position Contour**—See SAE J1052 (August, 1974), "Motor  $\phi$  Vehicle Driver and Passenger Head Position."

**3.8 Head Contour Locator Line—Fixed Seat**—See SAE J1052 (August, 1974).

**3.9 Eyellipse and Head Contour Locator Line**—See SAE J941  $\phi$  MAR81.

**3.10 T-Point**—Any point on the above 3.8 Head Contour Locator Line—Fixed Seat.

**3.11 H-Point**—The H-point is the pivot center of the torso and thigh on the two- or three-dimensional devices used in defining and measuring vehicle seating accommodation [See SAE J826b (January, 1974).]

**3.11.1 DESIGN H-POINT**—The design H-point is located on a drawing by the H-point on the two-dimensional drafting template placed in any designated seating position. If the designated seating position can be adjusted, the path of the design H-point through the full seat adjustment establishes the design H-point travel line, and can be dimensionally described by coordinates relative to the three-dimensional reference system.

**3.11.2 SEATING REFERENCE POINT (SgRP)**—The manufacturer's design reference point is a unique design H-point which:

(a) Establishes the rearmost normal design driving or riding position of each designated seating position, which includes consideration of all modes of adjustment, horizontal, vertical, and tilt, in a vehicle;

(b) Has X, Y, Z coordinates established relative to the designed vehicle structure;

(c) Simulates the position of the pivot center of the human torso and thigh; and

(d) Is the reference point employed to position the two-dimensional drafting template with the 95th percentile leg described in SAE J826  $\phi$  APR80.

**3.11.3 ACTUAL H-POINT**—The actual H-point is located in an actual vehicle by the H-point on the three-dimensional H-point machine with the 95th percentile leg installed in any designated seating position per instructions in SAE J826 APR80 and can be dimensionally located by  $\phi$  coordinates relative to the three-dimensional reference system.

**3.12 Designated Seating Position**—Any plan view location intended by the manufacturer to provide seating accommodation while the vehicle is in motion, for a person at least as large as a 5th percentile adult female, except auxiliary seating accommodations such as temporary or folding jump seats.

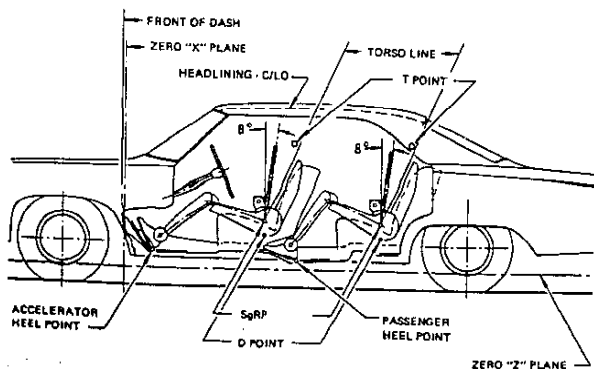

FIG. 1—REFERENCE POINTS

**3.13 D-Point**—D-point is the lowest point on the buttocks contour of the seated two- or three-dimensional device in the installed position. (See Fig. 1)

**3.14 Cowl Point**—Cowl point is a point on the rearmost exposed cowl sheet metal on the zero "Y" plane. In the case of a hidden wiper system, the point is on the windshield glazing at the height of the cowl panel, including molding on the zero "Y" plane. (See Fig. 23)

**3.15 Deck Point**—Deck point is a point on the foremost exposed upper back panel or tailgate sheet metal on the zero "Y" plane. In the case of a deck lid extending to the rear window, the point is on the rear-window glazing or rear-window glazing molding at the height of the deck lid panel, including moldings, on the zero "Y" plane. (See Fig. 23)

**3.16 Accelerator Heel Point (AHP)**—Accelerator heel point is located at the intersection of the two- or three-dimensional device heel point and the depressed floor covering with the shoe on the undepressed accelerator pedal and the foot angle at a minimum of 87 deg. For vehicles with SgRP to heel (H30) greater than 18 in, the accelerator pedal may be depressed as specified by the manufacturer. If the depressed pedal is used, the foot must be flat on the accelerator pedal. (See Fig. 1)

**3.17 Centerline of Occupant (C/LO)**—Centerline of occupant is the "Y" coordinate of the H-point, and is represented by the centerplane of the occupant or H-point machine in each designated seating position.

**3.18 Torso Line**—Torso line is the line on the two-dimensional drafting template connecting the shoulder reference point (see SAE J826 APR80) and the H-point (corresponds to centerline of headroom probe in full back position of H-point machine).

**3.19 Front of Dash**—Front of dash represents a vertical tangent to the foremost predominating surface of the dash panel at the centerline of driver, disregarding flanges and small localized formations. The dash panel is usually the vertical extension of the toe panel.

**3.20 Undepressed Floor Covering**—Undepressed floor covering is the surface of the floor covering at a designated point in the vehicle without any load applied to the covering.

**3.21 Depressed Floor Covering**—Depressed floor covering is the surface of the floor covering at a designated point in the vehicle, with a load applied to the covering as specified by the manufacturer.

**3.22 Daylight Opening (DLO)**—Daylight opening is the maximum unobstructed opening through any glass aperture, including reveal or garnish moldings adjoining the glass, according to a given direction or projection. If not specified, the dimension will be the horizontal projection.

**3.23 Thigh Centerline**—Line connecting H-point and knee pivot point. (See SAE J826 APR80.)

**3.24 Leg Centerline**—Line connecting knee pivot point and ankle pivot point. (See SAE J826 APR80.)

**3.25 Normal Top of Frame—Truck**—The longest normal surface of the top flange of the truck frame within the wheelbase.

**3.26 Cargo Floor**—The surface for supporting cargo including ribs or undepressed floor covering.

**4. Fiducial Mark Dimensions**

**4.1 Fiducial Mark—Number 1**

- L54—"X" coordinate.
- W21—"Y" coordinate.
- H81—"Z" coordinate.
- H161—Height "Z" coordinate to ground at curb weight.
- H163—Height "Z" coordinate to ground.

**4.2 Fiducial Mark—Number 2**

- L55—"X" coordinate.
- W22—"Y" coordinate.
- H82—"Z" coordinate.
- H162—Height "Z" coordinate to ground at curb weight.
- H164—Height "Z" coordinate to ground.

**4.3 Fiducial Mark—Number 3**

- L56—"X" coordinate.
- W23—"Y" coordinate.
- H83—"Z" coordinate.
- H167—Height "Z" coordinate to ground at curb weight.
- H168—Height "Z" coordinate to ground.

**5. Interior Dimensions**

**5.1 Front Seat Compartment Dimensions**—Driver unless otherwise specified. (See Figs. 2—7 and 9—13.)

**PD1**—Passenger distribution—front.

**H5**—SgRP—front to ground. The dimension measured vertically from the SgRP to ground.

**H26**—Interior body height—front at zero "Y" plane. The dimension measured along a line 8 deg rear of vertical which lies on the zero "Y" plane and passes through the SgRP—front "X" and "Z" coordinate from

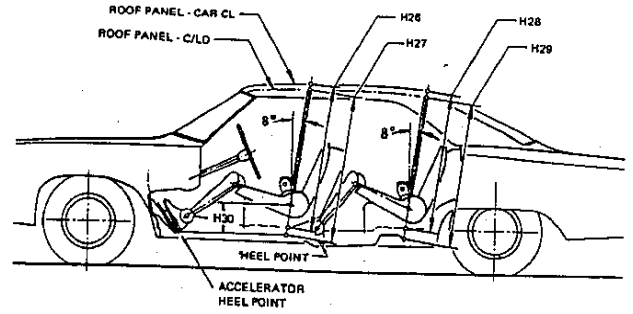

φFIG. 2—INTERIOR DIMENSIONS, HEIGHT

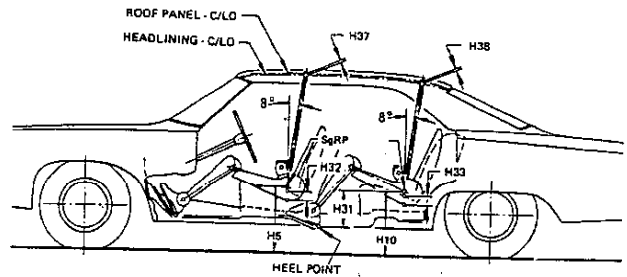

φFIG. 3—INTERIOR DIMENSIONS, HEIGHT

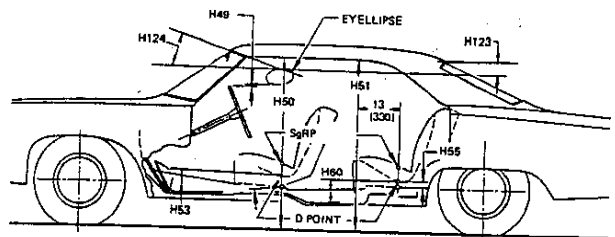

NOTE: DIMENSIONS ARE IN (mm)

φFIG. 4—INTERIOR DIMENSIONS, HEIGHT

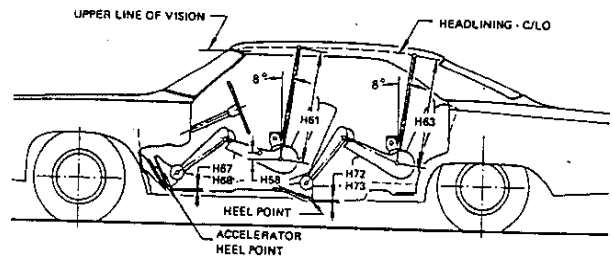

φFIG. 5—INTERIOR DIMENSIONS, HEIGHT

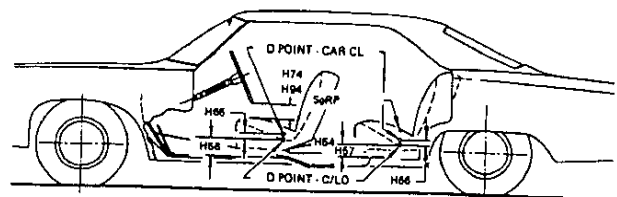

φFIG. 6—INTERIOR DIMENSIONS, HEIGHT

34.100

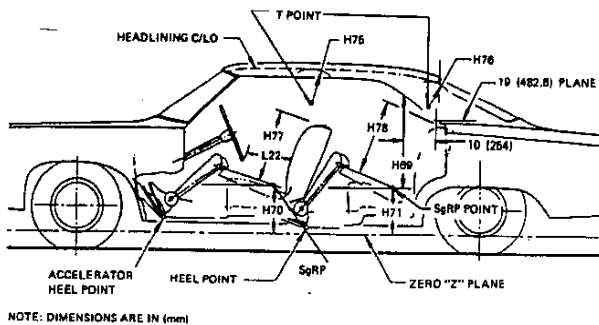

FIG. 7—INTERIOR DIMENSIONS, HEIGHT

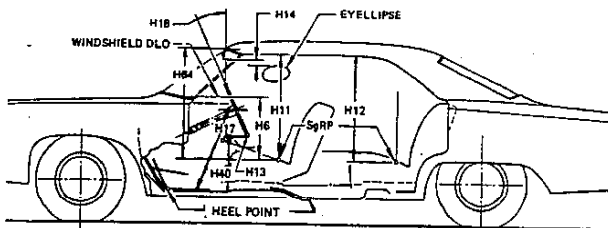

FIG. 8—INTERIOR DIMENSIONS, HEIGHT

the nearest obstruction or underbody sheet metal to the roof sheet metal.

**H27**—Interior body height—front—at SgRP "Y" plane. The dimension measured along a line 8 deg rear of vertical which passes through the SgRP—front from the nearest obstruction or underbody sheet metal to the roof sheet metal.

**H30**—SgRP—front to heel. The dimension measured vertically from the SgRP—front to the accelerator heel point.

**H35**—Driver head clearance to headlining. The vertical distance measured between the top of the 95th percentile driver head position contour and the interior surface.

**H37**—Headlining to roof panel—front. The dimension measured from the intersection of the headlining and the extended effective head room line normal to the sheet metal.

**H45**—Design H-point travel. The dimension measured vertically between the highest and lowest seat position.

**H53**—D-point—front to heel. The vertical dimension from the D-point to the accelerator heel point.

**H54**—D-point—center passenger—front to tunnel. The minimum dimension measured from the D-point—front to the underbody sheet metal at the zero "Y" plane.

**H56**—D-point—front to floor. The minimum dimension measured from

the D-point—front to the underbody sheet metal at the SgRP "Y" plane.

**H58**—Design H-point rise. The dimension measured vertically between the design H-point—front in the foremost and rearmost seat track positions.

**H59**—Normal driving and riding design H-point rise. The dimension measured vertically between the SgRP and the foremost design H-point in the normal driving and riding seat track travel (L23) position.

**H61**—Effective head room—front. The dimension measured along a line 8 deg rear of vertical from the SgRP—front to the headlining, plus 4.0 in (102 mm).

**H65**—D-point—front—differential, side to center. The dimension measured vertically from the driver D-point to the center occupant D-point.

**H67**—Floor covering thickness—undepressed—front. The dimension measured vertically from the surface of the undepressed floor covering to the underbody sheet metal at the accelerator heel point.

**H68**—Floor covering thickness—depressed—front. The dimension measured vertically from the accelerator heel point to the underbody sheet metal.

**H70**—SgRP—front, "Z" coordinate.

**H75**—Effective T-point head room—front. The minimum radius from the T-point to the headlining plus 30 in (762 mm).

**H79**—SgRP differential, side to center. The dimension measured vertically from the driver SgRP to the center occupant SgRP.

**H91**—Rearmost design H-point—front, "Z" coordinate.

**H311**—Engine cover height. The vertical dimension from accelerator heel point to top of engine cover.

**L17**—Design H-point—front travel. The dimension measured horizontally between the design H-point—front in the foremost and rearmost seat track positions.

**L23**—Normal driving and riding seat-track level. The dimension measured horizontally between a point on the design H-point travel line from the SgRP to the displaced point on the design H-point travel line with the seat moved to the foremost seat position, but not to include seat-track travel used for purposes other than normal driving and riding positions.

**L31**—SgRP—front, "X" coordinate.

**L34**—Maximum effective leg room—accelerator. The dimension measured along a line from the ankle pivot center to the SgRP—front plus 10.0 in (254 mm) measured with right foot on the undepressed accelerator pedal. For vehicles with SgRP to heel (H30) greater than 18 in, the accelerator pedal may be depressed as specified by the manufacturer. If the accelerator is depressed, the manufacturer shall place foot flat on pedal and note the depression of the pedal.

**L37**—Rearmost design H-point—front, "X" coordinate.

**L38**—Driver head clearance to windshield garnish. The minimum distance measured between the SAE 95th percentile driver head position contour—side view, and the windshield garnish molding, weatherstrip, or glazing surface on the Y-plane intersecting the rear view top of contour.

**L40**—Back angle—front. The angle measured between a vertical line through the SgRP—front and the torso line. If the seatback is adjustable, use the normal driving and riding position specified by the manufacturer.

**L42**—Hip angle—front. The angle measured between torso line and thigh centerline.

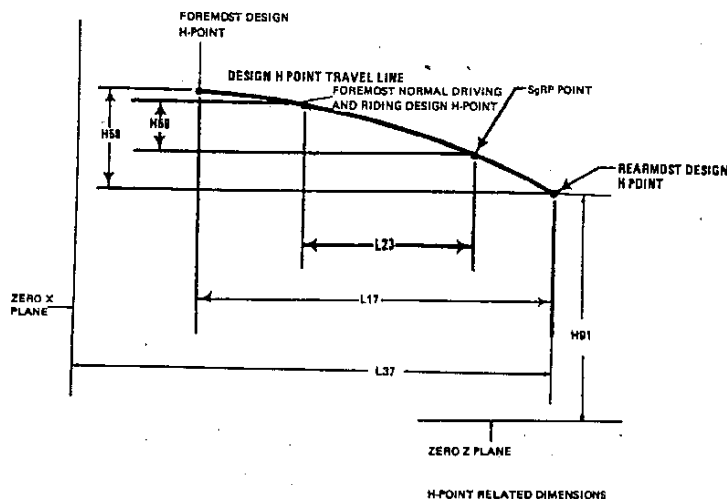

FIG. 9—H-POINT RELATED DIMENSIONS

- L44**—Knee angle—front. The angle measured between thigh centerline and lower leg centerline measured on the right leg.
- L46**—Foot angle—front. The angle measured between the lower leg centerline and a line tangent to the ball and heel of the bare measured  $\phi$  on the right leg (Reference J826 APR80.)
- L53**—SgRP—front to heel. The dimension measured horizontally from the SgRP—front to the accelerator heel point.
- $\phi$  **L62**—Knee clearance—front. The minimum dimension measured in the side view from the knee pivot center to the nearest interference minus 2.0 in (51 mm). The center of knee pivots are laterally separated for proper foot placement. The right pivot is with the right foot lined up on the accelerator and the left pivot is with the left foot on the floor in line with the clutch pedal.
- L114**—Front wheel C/L to front SgRP. The horizontal dimension measured between the front wheel centerline and the SgRP.
- L308**—Engine cover length. The maximum dimension measured horizontally from front of dash to rear of engine cover, excluding the flanges at floor.
- W3**—Shoulder room—front. The minimum dimension measured laterally between the trimmed door or quarter trim surfaces on the "X" plane through the SgRP—front at the height between the belt line and 10.0 in (254 mm) above the SgRP—front, excluding the door assist strap and attaching parts.
- W3**—Hip room—front. The minimum dimension measured laterally between the trimmed surfaces on the "X" plane through the SgRP—front within 1.0 in (25 mm) below and 3.0 in (76 mm) above the SgRP—front and 3.0 in (76 mm) fore and aft of the SgRP—front.
- W20**—SgRP—front, "Y" coordinate.
- W24**—Rearmost design H-point—front, "Y" coordinate.
- W32**—Driver head clearance to roof-rail garnish. The minimum distance measured between the SAE 95th percentile driver head position contour—rear view and the roof-rail garnish molding, weatherstrip, or glazing surface on the X-plane intersecting the side view top of contour.
- W38**—Driver head clearance—minimum. The minimum distance measured between the SAE 95th percentile driver head position contour—rear view and the interior surface on the X-plane intersecting the side view top of contour.
- W300**—Engine cover width—left. The maximum dimension measured laterally between the zero "Y" plane and the left side of engine cover, excluding flanges at floor.
- W301**—Engine cover width—right. The maximum dimension measured laterally between the zero "Y" plane and the right side of the engine cover, excluding flanges at floor.
- 5.2 Second Seat Compartment Dimensions** (Left outboard passenger unless otherwise specified)
- PD2**—Passenger distribution—second.
- H10**—SgRP—second to ground. Measured in the same manner as H5.
- H28**—Interior body height—second at zero "Y" plane. The dimension measured along a line 8 deg rear of vertical which lies on the zero "Y" plane and passes through the SgRP—second "X" and "Z" coordinates, from the underbody sheet metal to the roof sheet metal.
- H29**—Interior body height—second at SgRP "Y" plane. The dimension measured along a line 8 deg rear of vertical which passes through the SgRP—second from the underbody sheet metal to the roof sheet metal.
- H31**—SgRP—second to heel. The dimension measured vertically from the SgRP—second to the two-dimensional device heel point on the depressed floor covering.
- H36**—Head clearance to headlining—second. The vertical distance measured between the top of the SAE 95th percentile head position contour and headlining.
- H38**—Headlining to roof panel—second. The dimension measured from the intersection of the headlining and the extended effective head room line normally to the roof sheet metal.
- H55**—D-point—center passenger—second to tunnel. The minimum dimension measured from the D-point to the underbody sheet metal at the zero "Y" plane.
- H57**—D-point—second to floor. The minimum dimension measured from the D-point to the underbody sheet metal at the SgRP "Y" plane.
- H60**—D-point to heel point—second. The vertical dimension from the D-point to heel point with the front seat in rearmost position.
- H63**—Effective head room—second. The dimension measured along a line 8 deg rear of vertical from the SgRP to the headlining, plus 4.0 in (102 mm).
- H66**—D-point—differential, side to center—second. The dimension measured vertically from D-point to the center occupant D-point.
- H71**—SgRP—second, "Z" coordinate.
- H72**—Floor covering thickness—undepressed—second. The dimension measured vertically from the surface of the undepressed floor covering to the underbody sheet metal at the heel point.
- H73**—Floor covering—depressed—second. The dimension measured vertically from the heel point to the underbody sheet metal.
- H76**—Effective T-point head room—second. Measured in the same manner as H75.
- H80**—SgRP—differential, side to center—second. The dimension measured vertically from the SgRP—second to the center occupant SgRP—second.
- L3**—Compartment room—second. The dimension measured horizontally from the back of front seat to the front of the second seatback at a height tangent to the top of the second seat cushion.
- L32**—SgRP—second to rear wheel centerline. The dimension measured horizontally from the SgRP—second to the centerline of the rear wheels.
- L35**—SgRP—second, "X" coordinate.
- L39**—Head clearance to back window garnish. The minimum distance measured between the SAE 95th percentile head position contour—side view and the back window, garnish molding, weatherstrip, or glazing surface on the Y-plane intersecting the rear view top of contour.
- L41**—Back angle—second. The angle measured between a vertical line through the SgRP—second and the torso line.
- L43**—Hip angle—second. The angle measured between torso line and thigh centerline.
- L45**—Knee angle—second. The angle measured between thigh centerline and lower leg centerline.
- L47**—Foot angle—second. The angle measured between the lower leg centerline and a line tangent to the ball and heel of the three-dimensional devices bare foot flesh line. (Reference J826 APR80.)
- L48**—Knee clearance—second. The minimum dimension measured from the knee pivot center to the back of front seatback, minus 2.0 in (51 mm).
- L50**—SgRP couple distance. The dimension measured horizontally from the driver SgRP—front to the SgRP—second.
- L51**—Minimum effective leg room—second. The dimension measured along a line from the ankle pivot center to the SgRP—second plus 10.0 in (254 mm).
- W4**—Shoulder room—second. The minimum dimension measured laterally between the trimmed-door or quarter-trim surfaces on the "X" plane through the SgRP—second at a height between 10.0–16.0 in (254–406

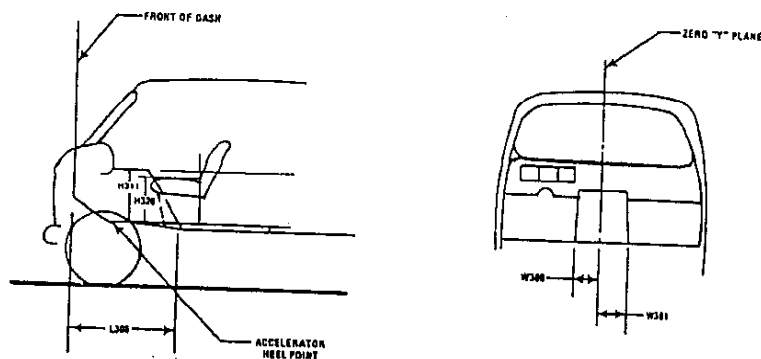
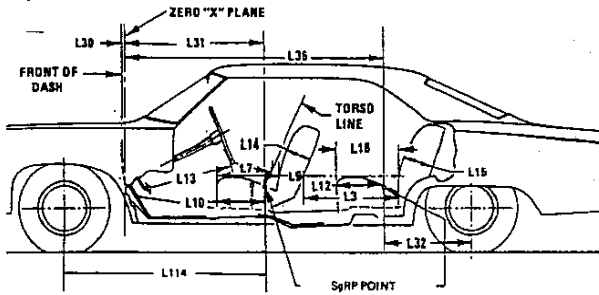
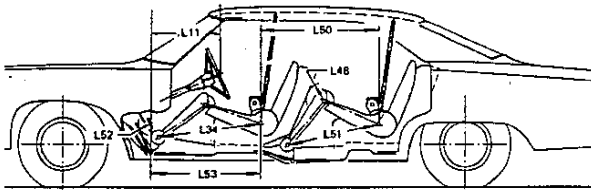

FIG. 10—INTERIOR DIMENSIONS, ENGINE COMPARTMENT

34.102



φFIG. 11—INTERIOR DIMENSIONS, LENGTH



φFIG. 12—INTERIOR DIMENSIONS, LENGTH

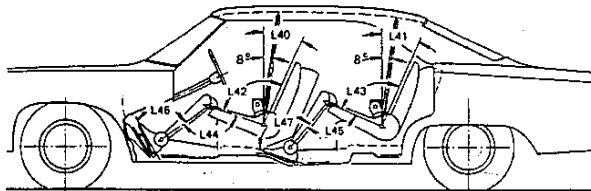

φFIG. 13—INTERIOR DIMENSIONS, LENGTH

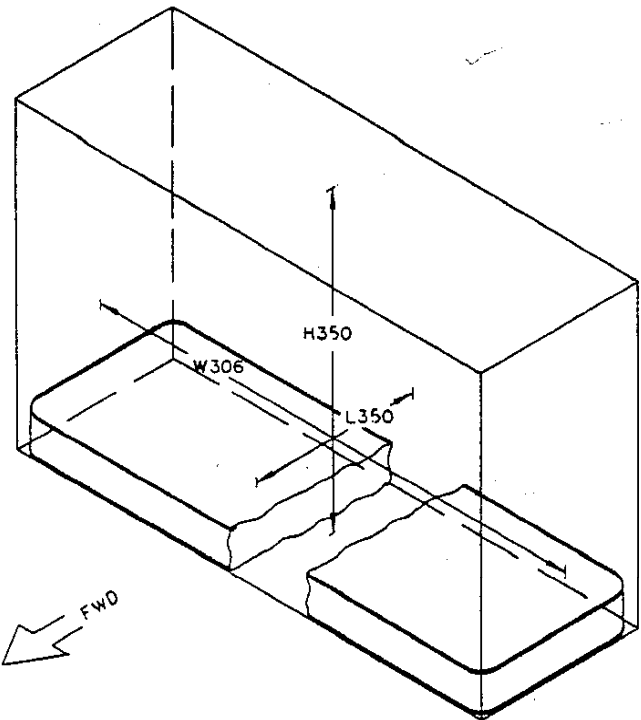

φFIG. 15—TRUCK SLEEPER COMPARTMENT

mm) above the SgRP—second, excluding the door-assist strap and attaching parts.

W6—Hip room—second. Measured in the same manner as W5.  
W25—SgRP—second, "Y" coordinate.

W33—Head clearance to roof-rail garnish—second. The minimum distance measured between the SAE 95th percentile head position contour—rear view and the roof-rail garnish molding, weatherstrip, or glazing surface on the X-plane intersecting the side view top of contour.

W39—Head clearance—minimum—second. The minimum distance measured between the SAE 95th percentile head position contour—rear view and the interior surface of the X-plane intersecting the side view top of contour.

φ 5.2.1 TRUCK SLEEPER COMPARTMENT DIMENSIONS—See Fig. 15.

φ H350—Height of Sleeper Compartment "Z" Coordinate. The minimum dimension from undepressed compartment overhead-trim panel to compartment floor (mattress base). This dimension shall be taken along the longitudinal centerline of the vehicle at a point 1/2 the compartment length (L350).

φ L350—Sleeper Compartment "X" Coordinate. The dimension of the sleeper compartment taken at the compartment longitudinal centerline, with the soft trim undepressed. Dimension shall be taken from the back

of the cab to the forward edge of the mattress support surface. (Truck definition: sleeper width).

W306—Sleeper Compartment "Y" Coordinate. The dimension of the sleeper compartment taken between undepressed side-trim panels and perpendicular to the vehicle longitudinal centerline. This dimension shall be taken 12 in (305 mm) above the compartment floor (mattress base) along the longitudinal centerline of the vehicle, at a point 1/2 the compartment length (L350). (Truck definition: sleeper length).

5.3 Third Seat Compartment Dimensions—Left outboard forward-facing passenger unless otherwise specified. (See Fig. 16.)

PD3—Passenger distribution—third.

SD1—Seat facing direction—third.

H39—Head clearance to headlining—third. The vertical distance measured between the top of the SAE 95th percentile head position contour and the headlining.

H62—D-point to heel point—third. Measured in the same manner as H60.

H88—SgRP—third "Z" coordinate.

H85—SgRP—third to ground.

H87—SgRP—third to heel point.

H86—Effective head room—third. The dimension measured along a line 8 deg from the SgRP—third to the headlining rear of vertical plus a constant of 4.0 in (102 mm).

H84—Headlining to roof—third. Measured in the same manner as H38.

H89—Effective T-point head room—third. Measured in the same manner as H75.

H90—D-point—third to floor. Measured in the same manner as H57.

L36—SgRP—third "X" coordinate.

L85—SgRP couple distance—third. The dimension measured horizontally from the SgRP—second to the SgRP—third.

L86—Effective leg room—third. The dimension measured along a line from the angle pivot center to the SgRP—third plus 10.0 in (254 mm).

L87—Knee clearance—third. The minimum dimension from the knee pivot center to the back of second seatback minus a constant of 2.0 in (51 mm). With rear-facing third seat, dimension is measured to closure.

L88—Back angle—third. Measured in the same manner as L41.

L89—Hip angle—third. Measured in the same manner as L43.

L90—Knee angle—third. Measured in the same manner as L45.

L91—Foot angle—third. Measured in the same manner as L47.

L92—Compartment room—third. The horizontal dimension from the

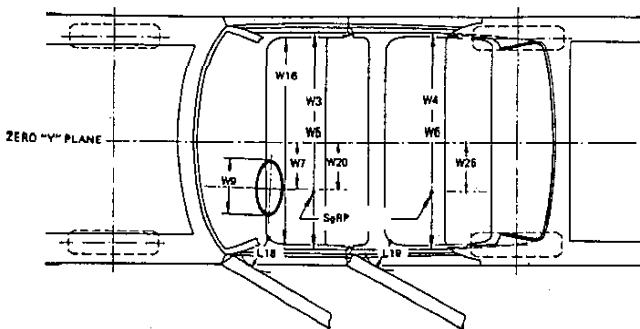

φFIG. 14—INTERIOR DIMENSIONS, WIDTH

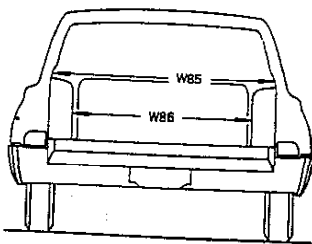
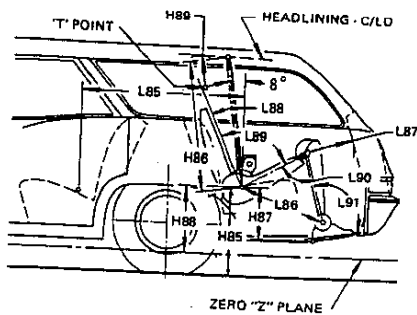

FIG. 16—INTERIOR DIMENSIONS, STATION WAGON THIRD SEAT

back of the second seat to the front of the third seatback, at a height tangent to the top of the third seat cushion. For rear-facing third seat, measure to the closure.

**W26**—SgRP—third "Y" coordinate.

**W34**—Head clearance to roof-rail garnish—third. The minimum distance measured between the SAE 95th percentile head position contour—rear view and the roof-rail garnish molding, weatherstrip, or glazing surface on the X-plane intersecting the side view top of contour.

**W40**—Head clearance—minimum—third. The minimum distance measured between the SAE 95th percentile head position contour—rear view and the vehicle interior on the X-plane intersecting the side view top of contour.

**W85**—Shoulder room—third. Measured in the same manner as W4.

**W86**—Hip room—third. Measured in the same manner as W5.

**5.4 Seat, Entrance and Exit Dimensions** (See Figs. 8, 14, 20, and 22.)

**H11**—Entrance height—front. The dimension measured vertically from the SgRP—front "X" plane to the upper trimmed body opening at SgRP station.

**H12**—Entrance height—second. The dimension measured vertically from the SgRP—second to the upper trimmed body opening at a section 13 in (330 mm) forward of the SgRP.

**H32**—Cushion deflection—front. The dimension measured vertically from the free to the depressed front seat cushion [see SAE J826b (January, 1974)] on the SgRP—front "Y" plane.

**H33**—Cushion deflection—second. The dimension measured vertically from the free to the depressed second seat cushion [see SAE J826b (January, 1974)] SgRP—second "Y" plane.

**H34**—Cushion deflection—third. The dimension measured vertically from the free to the depressed third seat cushion [see SAE J826b (January, 1974)] on the SgRP—third "Y" plane.

**H40**—Steering wheel to accelerator heel point. The minimum vertical dimension measured from the lowest edge of the steering wheel, in the straight ahead position, to the accelerator heel point.

**H50**—Upper-body opening to ground—front. The dimension measured vertically from the trimmed body opening to the ground on the SgRP—front "X" plane.

**H51**—Upper-body opening to ground—second. The dimension measured vertically from the trimmed body opening to the ground on the "X" plane 13.0 in (330 mm) forward of the SgRP—second.

**H69**—Exit height—second. The dimension measured vertically from the SgRP—second to the upper trimmed body opening 10 in (254 mm) forward of the intersection of the trimmed body opening and a horizontal plane 19 in (483 mm) above the SgRP—second seat.

**H74**—Steering wheel to cushion. The minimum dimension measured

between the steering wheel, with the front wheels in the straight-ahead position, and the undepressed seat cushion on the steering wheel center "Y" plane.

**H77**—Seatback height—front. A dimension measured along the torso line from the SgRP—front to a line normal to the torso line and tangent to the top of the seatback soft trim or head restraint in the stowed position.

**H78**—Seatback height—second. A dimension measured along the torso line from the SgRP—second seat to a line normal to the torso line and tangent to the top of the seatback soft trim.

**H92**—Seatback height—third. A dimension measured along the torso line from the SgRP—third seat to a line normal to the torso line and tangent to the top of the seatback soft trim.

**H94**—Steering wheel to cushion—minimum. The minimum dimension measured between the steering wheel, with the steering wheel turned to its lower position, and the undepressed seat cushion on the steering wheel center "Y" plane.

**H115**—Step height—front. The dimension will be to the top of the sill plate bead at the center of the lower door opening. If there is a step, the dimension is measured vertically from the ground to the first step entering the vehicle.

**H116**—Step height—second. The dimension will be to the top of the sill plate bead at the center of the lower door opening. If there is a step, the dimension is measured vertically from the ground to the first step entering the vehicle.

**H130**—Step height—front (curb weight). The dimension will be to the top of the sill plate bead at the center of the lower door opening. If there is a step, the dimension is measured vertically from the ground to the first step entering the vehicle.

**H131**—Step height—second (curb weight). The dimension will be to the top of the sill plate bead at the center of the lower door opening. If there is a step, the dimension is measured vertically from the ground to the first step entering the vehicle.

**H326**—Seat cushion height—front. The vertical dimension from the point of intersection of the horizontal tangent to the top of the seat cushion and the vertical tangent to the front of the seat cushion, to accelerator heel point.

**H445**—Second step height—front. The vertical dimension from the first step entering vehicle to second step. If there is no second step, the dimension will be to the top of the sill plate bead at the center of the lower door opening.

**H446**—Second step height—second. The vertical dimension from the first step entering vehicle to second step. If there is no second step, the dimension will be to the top of the sill plate bead at the center of the lower door opening.

**L9**—Cushion depth—front. The dimension measured horizontally from the front edge of the cushion to an "X" plane tangent to the undepressed seatback at a height tangent to the top of the seat cushion.

**L10**—Effective cushion depth—front. The dimension measured horizontally from the front edge of the cushion to the SgRP.

**L12**—Effective cushion depth—second. The dimension measured horizontally from the front edge of the cushion to the SgRP.

**L14**—Seatback thickness—front. The maximum dimension measured through the front seatback, excluding bolsters.

**L15**—Seatback thickness—second. The maximum dimension measured through the second seatback, excluding bolsters.

**L16**—Cushion depth—second. The dimension measured horizontally from the front edge of the cushion to an "X" plane tangent to the undepressed seatback at a height tangent to the top of the seat cushion.

**L18**—Entrance foot clearance—front. The minimum dimension measured horizontally between the trimmed front seat cushion frame or supporting structure and the trimmed door or pillar at a height between the sill plate bead and 4.0 in (102 mm) above the bead with the door in the maximum hold-open position.

**L19**—Entrance foot clearance—second.

**Four-Door Models**—Same as L18.

**Two-Door Models**—The minimum dimension measured horizontally between the trimmed front seat with front seatback tilted forward, and the trimmed lock pillar, trimmed quarter panel, or trimmed rear seat cushion at a height between the sill plate bead and 4.0 in (102 mm) above the bead with the door in the maximum hold-open position.

**L20**—Seatback thickness—third. The maximum dimension measured through the third seatback, excluding bolsters.

**L21**—Cushion depth—third. The dimension measured horizontally from the front edge of the cushion to an "X" plane tangent to the undepressed seatback at a height tangent to the seat cushion.

**L22**—Steering wheel to seatback. The minimum distance measured between the steering wheel, in its straight ahead position, and the undepressed seatback on the steering wheel center "Y" plane.

34.104

**L24**—Effective cushion depth—third. The dimension measured horizontally from the front edge of the cushion to the SgRP.

**W16**—Cushion width—front. The maximum dimension measured laterally across the trimmed width of the front seat cushion.

**5.5 Vision and Control Dimensions**—Driver unless otherwise specified. (See Figs. 17 and 18.)

**H6**—SgRP—front to windshield lower DLO. The dimension measured vertically from the SgRP—front to the windshield lower or hood molding DLO at C/LO.

**H13**—Steering wheel to centerline of thigh. The minimum dimension measured from the bottom of steering wheel, with front wheels in the straight position, to the thigh centerline.

**H14**—Eyellipse to bottom of inside rear-view mirror. The dimension measured vertically from a horizontal plane tangent to the top of the SAE 95th percentile eyellipse to the bottom edge of rear-view mirror frame in the lowest usable position of adjustment. A minus (–) dimension indicates the mirror is located below the horizontal plane. (If the mirror is located on the instrument panel, the dimension will be measured from the top of the mirror frame in the highest usable position to the bottom of SAE 95th percentile eyellipse.)

**H17**—Accelerator heel point to the steering wheel center. The dimension measured vertically from the AHP—front to the intersection of the steering column centerline to a plane tangent to the upper surface of the steering wheel rim.

**NOTE:** The steering column center is used instead of the wheel center to eliminate error that could occur with a non-symmetrical steering wheel.

**H18**—Steering wheel angle. The angle measured from a vertical to the surface plane of the steering wheel.

**H25**—Belt height—front. The dimension measured vertically from the SgRP—front to the bottom of the side window DLO at SgRP “X” plane.

**H49**—Eyellipse to top of steering wheel. The dimension measured vertically from a horizontal plane tangent to the bottom of the SAE 95th percentile eyellipse to the top of the steering wheel, in the straight-ahead position. A minus (–) dimension indicates the bottom of the eyellipse is located below the top of the steering wheel.

**H64**—SgRP—front to windshield upper DLO. The dimension measured vertically from the SgRP—front to the windshield upper DLO at C/LO.

**H121**—Backlight slope angle. The angle between the vertical reference line and the surface of backlight at vehicle zero “Y” plane. For curve backlight, the angle is to chord of backlight arc from lower DLO to upper DLO.

**H122**—Windshield slope angle. The angle between the vertical reference line and a chord of the windshield arc running from the lower DLO to the upper DLO at the vehicle zero “Y” plane. In the case of wrap-over glass, the angle to be measured will be formed by a chord 18.0 in (457 mm) long, drawn from the lower DLO to the intersecting point on the windshield.

**H123**—Eyellipse to backlight upper opening. The vertical distance from a horizontal plane tangent to the top of the SAE 95th percentile eyellipse to the highest horizontal line of vision through the backlight upper trimmed body opening at zero “Y” plane.

**H124**—Vision angle to windshield upper DLO. The angle from the horizontal to a plane tangent to the top of the SAE 95th percentile eyellipse and to the upper trimmed body opening measured at C/LO.

**L7**—Steering wheel torso clearance. The minimum dimension measured in the side view from the rearmost edge of the steering wheel, with front wheels in the straight ahead position, to the torso line.

**L11**—Accelerator heel point to steering wheel center. The dimension measured horizontally from the AHP to the intersection of the steering column centerline and a plane tangent to the upper surface of the steering wheel rim.

**L13**—Brake pedal knee clearance. The minimum dimension measured in side view from the lower edge of the steering wheel rim to the centerline of the brake pedal face with pedals in the free position.

**L52**—Brake pedal to accelerator. The minimum dimension measured in the side view from the center of the brake pedal face to the center of the accelerator pedal face with pedals in free position. A minus (–) dimension indicates that the brake pedal is lower than the accelerator pedal.

**L324**—SgRP to windshield upper DLO. The horizontal dimension from the SgRP to the point of tangency of the horizontal line of vision (described in dimension H64) to body upper structure.

φ **L330**—Clutch pedal to steering wheel clearance. The minimum dimension in side view from the lower edge of the steering wheel rim to the centerline of the clutch pedal face with pedal in the free or undepressed position.

φ **L331**—Brake pedal to steering wheel clearance. The minimum dimen-

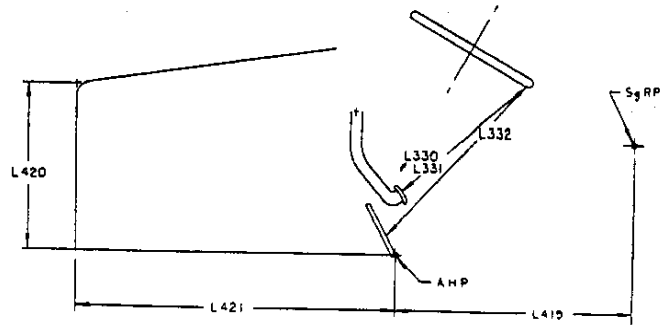

φFIG. 17—PEDALS TO STEERING WHEEL CLEARANCE

sion in side view from the lower edge of the steering wheel rim to the centerline of the brake pedal face with pedal in the free or undepressed position.

**L332**—Accelerator pedal to steering wheel clearance. The minimum dimension in side view from the lower edge of the steering wheel rim to the centerline of the accelerator pedal face with pedal in the free or undepressed position.

**W7**—Steering wheel center “Y” coordinate. The steering column center is the point located by the intersection of the steering column axis with the plane tangent to the upper surface of the steering wheel rim.

**W9**—Steering wheel maximum outside diameter. Define if other than round.

**W41**—Side glass radius. Specify location.

**W30**—Steering wheel to door clearance. The minimum dimension from the steering wheel rim to the nearest body obstruction. Specify location.

**122**—Tumble-home.

**Straight Side Glass**—The angle measured from a vertical to the outside surface of the front door glass at the SgRP “X” plane.

**Curved Side Glass**—The angle measured from a vertical to a chord extending from the upper DLO to the lower DLO, at the outside surface of the front door glass at the front SgRP “X” plane.

## 6. Exterior Dimensions

### 6.1 Exterior Width Dimensions (See Fig. 19.)

**H114**—Cowl point to ground. Measured at zero “Y” plane.

**W101**—Tread—front. The dimension measured between the tire centerlines at the ground.

**W102**—Tread—rear. The dimension measured between the tire centerlines at the ground. In case of dual wheels, the dimension will be measured to the centerline of tire and wheel assemblies.

**W103**—Vehicle width. The maximum dimension measured between the widest point on the vehicle, excluding exterior mirrors, flexible mud flaps, and marker lamps, but including bumpers, moldings, sheet metal protrusions, or dual wheels, if standard equipment.

**W106**—Front fender width. The dimension measured between the widest points at the front wheel centerline, excluding moldings.

**W107**—Rear fender width. The dimension measured between the widest points at the rear wheel centerline, excluding moldings.

**W116**—Body width—maximum. The dimension measured between the widest point on the body, excluding mirrors, hardware, and applied moldings, but including fenders when integral with body.

**W117**—Body width at SgRP—front. The dimension measured laterally between the widest points on the body at the SgRP—front, excluding door handles, applied moldings, or appliques.

**W120**—Vehicle width—front doors open. The dimension measured between the widest point on the front doors in maximum hold-open position.

**W121**—Vehicle width—rear doors open. The dimension measured between the widest point on the rear doors in maximum hold-open position. For vehicles with a rear door on only one side, this dimension is to the zero “Y” plane.

**W409**—Vehicle width—tail doors open. The dimension measured between the widest point on the tail doors in the maximum hold-open position.

**W410**—Outside mirror width. The dimension measured between the widest point on the outside mirrors. The standard right and left mirror adjusted for normal driving will be shown unless otherwise noted. When only one outside mirror is standard, the dimension will be to the zero “Y” plane.

### 6.2 Exterior Height Dimensions (See Figs. 21 and 25.)



34.105

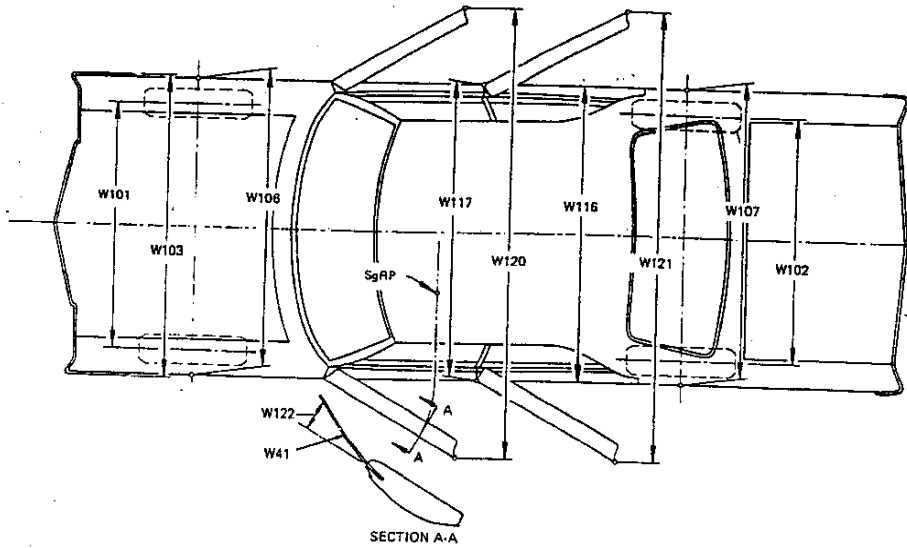

FIG. 18—EXTERIOR DIMENSIONS, WIDTH

**H101**—Vehicle height. The dimension measured vertically from the highest point on the vehicle body to ground.

**H111**—Rocker panel—rear to ground. The dimension measured vertically from the bottom of the rocker or side quarter panel at the front of the rear wheel opening, excluding flanges, to ground.

**H112**—Rocker panel—front to ground. The dimension measured vertically from the foremost point on the bottom of the rocker panel, excluding flanges, to ground.

**H125**—Headlamp to ground. The dimension measured vertically from the centerline of the lowest headlamp lens to ground.

**H126**—Taillamp to ground. The dimension measured vertically from the centerline of the upper bulb to ground.

**H127**—Headlamp to ground—curb weight. The dimension measured vertically from the centerline of the lowest headlamp lens to ground.

**H128**—Taillamp to ground—curb weight. The dimension measured vertically from the centerline of the upper bulb to ground.

**H132**—Bottom of door open—front to ground. The dimension measured vertically from the bottom outside corner of the door on the lock pillar side, in maximum hold-open position, to ground.

**H133**—Bottom of door closed—front to ground. The dimension measured vertically from the bottom outside corner of the door on the lock pillar side, in maximum closed position, to ground.

**H134**—Bottom of door open—rear to ground. The dimension measured vertically from the bottom outside corner of the door on the lock pillar side, in maximum hold-open position, to ground.

**H135**—Bottom of door closed—rear to ground. The dimension mea-

asured vertically from the bottom outside corner of the door on the lock pillar side, in maximum closed position, to ground.

**H136**—Zero "Z" plane to ground—front. The dimension measured vertically at front wheel centerline to ground.

**H137**—Zero "Z" plane to ground—rear. The dimension measured vertically at rear wheel centerline to ground. In the case of dual rear axes, the dimension will be taken at centerline between the rear wheels.

**H138**—Deck point to ground. Measured at zero "Y" plane.

**H139**—Bottom of door ajar, front to ground. The dimension measured vertically from the bottom outside corner of the door on the lock pillar side, open 10 in (254 mm) to the ground.

**H140**—Bottom of door ajar—rear to ground. The dimension measured vertically from the bottom outside corner of the door on the lock pillar side, open 10 in (254 mm) to ground.

**H158**—Roof thickness. The dimension measured vertically from the top of the roof to the upper DLO at the 50.0 in (1270 mm), "X" plane SgRP station, or less, if DLO obscured.

**H159**—Side glass height. The dimension measured vertically between the upper and lower DLO at the 50.0 in (1270 mm), "X" plane SgRP station, or less, if DLO obscured.

**H160**—Body thickness. The dimension measured vertically from the lower DLO to the bottom of the rocker panel, excluding any flanges, at the 50.0 in (1270 mm), "X" plane SgRP station, or less, unless otherwise specified.

**H195**—Liftover height. The dimension measured vertically from the luggage compartment lower opening at the zero "Y" plane to ground.

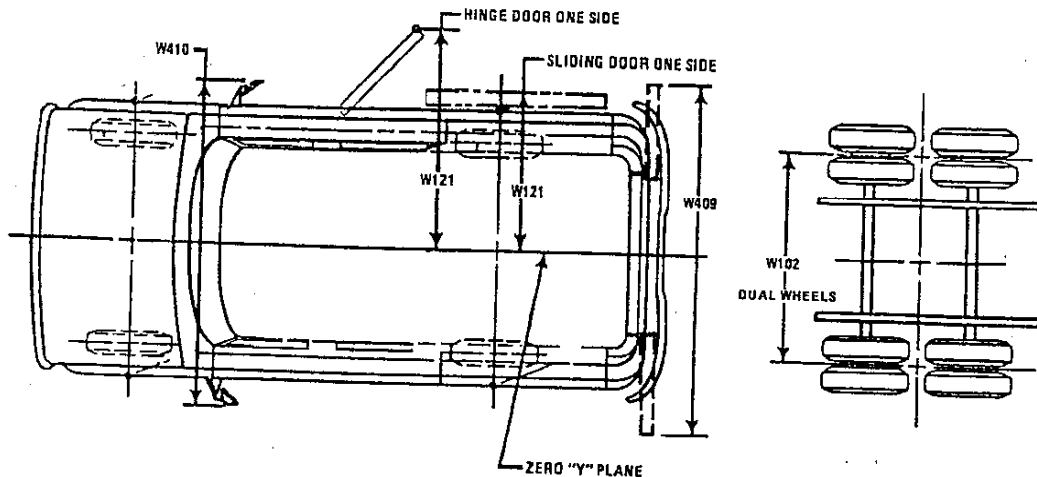
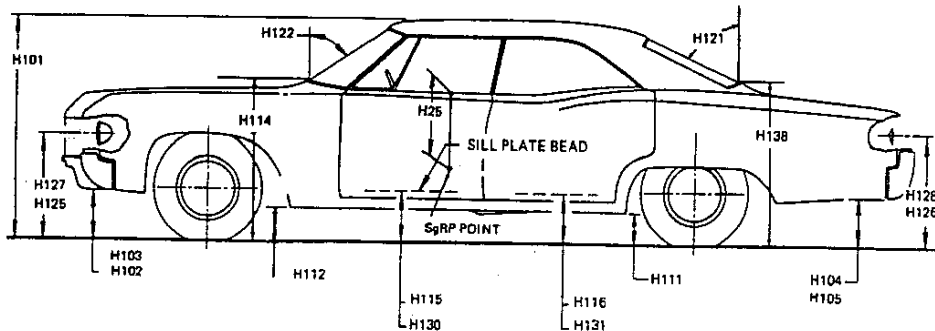

FIG. 19—EXTERIOR DIMENSIONS, WIDTH—TRUCK

34.106



φFIG. 20—EXTERIOR DIMENSIONS, HEIGHT

**H196**—Liftover height—curb weight. The dimension measured vertically from the luggage compartment lower opening at the zero "Y" plane to ground.

**H404**—Maximum overall height—tilt cab servicing. The vertical dimension from the highest point on the cab to ground, including exhaust outlet or other attached components, measured at the point of maximum height during tilting of the cab.

**H430**—Body height. The "Z" coordinate of highest point of roof.

**H431**—Vehicle height (curb weight). The dimension measured vertically from the highest point on the vehicle body to ground.

**H436**—Zero "Z" plane to ground—front (curb weight). The dimension measured vertically at front wheel centerline to ground.

**H437**—Zero "Z" plane to ground—rear (curb weight). The dimension measured vertically at rear wheel centerline to ground. In the case of dual rear axles, the dimension will be taken at centerline between the rear wheels.

**6.3 Exterior Length Dimensions (See Figs. 23 and 24.)**

**L30**—Front of dash "X" coordinate. A minus (-) dimension indicates actual front of dash is forward of the zero "X" plane.

**L101**—Wheelbase (WB). The dimension measured longitudinally between front and rear wheel centerlines. In case of dual rear axles, the dimension shall be to the midpoint of the centerlines of the rear wheels.

**L103**—Vehicle length. The maximum dimension measured longitudinally between the foremost point and the rearmost point on the vehicle, including bumper, bumper guards, tow hooks and/or rub strips, if standard equipment.

**L104**—Overhang—front. The dimension measured longitudinally from the centerline of the front wheels to the foremost point on the vehicle, including bumper, bumper guards, tow hooks, and/or rub strips, if standard equipment.

**L105**—Overhang—rear. The dimension measured longitudinally from

the centerline of the rear wheels; or in the case of dual rear axles, the dimension shall be the midpoint of the centerlines of the rear wheels, to the rearmost point on the vehicle, including rear bumpers, bumper guards, tow hooks, and rub strips, if standard equipment.

**L106**—Overhang—front—RPO. This dimension is measured the same as L104, except all RPO items are included.

**L107**—Overhang—rear—RPO. This dimension is measured the same as L105, except all RPO items are included.

**L108**—Vehicle length—RPO. This dimension is measured the same as L103, except all RPO items are included.

**L123**—Upper structure length. The dimension measured longitudinally from the cowl point to the deck point.

**L125**—Cowl point "X" coordinate.

**L126**—Front end length. The dimension measured longitudinally from the cowl point to the foremost point on the vehicle at the zero "Y" plane, excluding ornamentation or bumpers. In cases where bumpers and/or grills are integrated with the profile, measurement is made at the foremost point of front end contour.

**L127**—Rear wheel centerline "X" coordinate or in the case of dual rear axles, the coordinate shall be the midpoint of the distance between the rear axle centerlines.

**L128**—Front wheel centerline "X" coordinate.

**L129**—Rear end length. The dimension measured longitudinally from the deck point to the rearmost visible point of the body sheet metal at the zero "Y" plane, excluding ornamentation or bumpers.

**L403**—Front of bumper to back of cab (BBC). A horizontal dimension from the front of the front bumper to the back of cab at zero "Y" plane.

**L404**—Cab to rear axle (CA). A horizontal dimension from the rear of the cab to the centerline of the rear axle. In the case of dual rear axles, the dimension shall be to their midpoint.

**L408**—Front bumper to cab—tilt cab servicing position. The horizontal

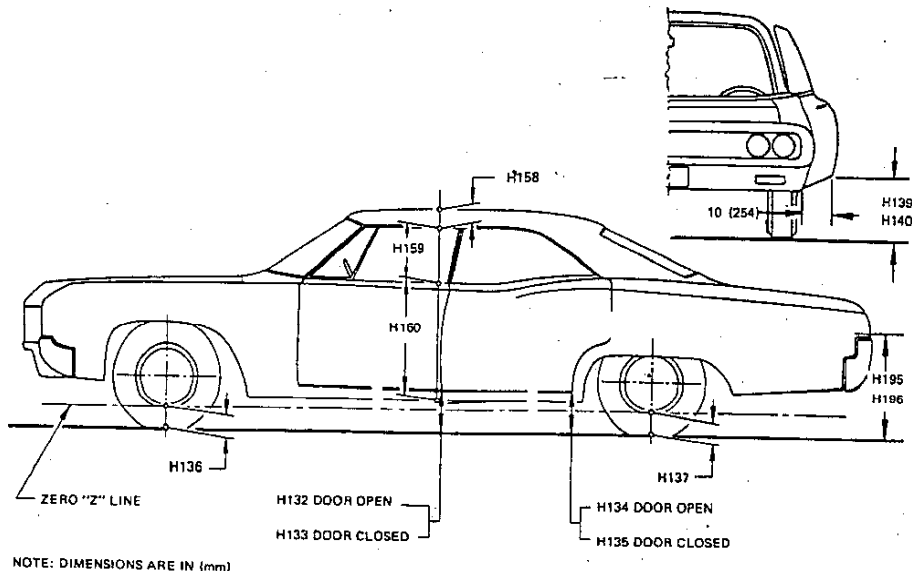

NOTE: DIMENSIONS ARE IN (mm)

φFIG. 21—EXTERIOR DIMENSIONS, HEIGHT

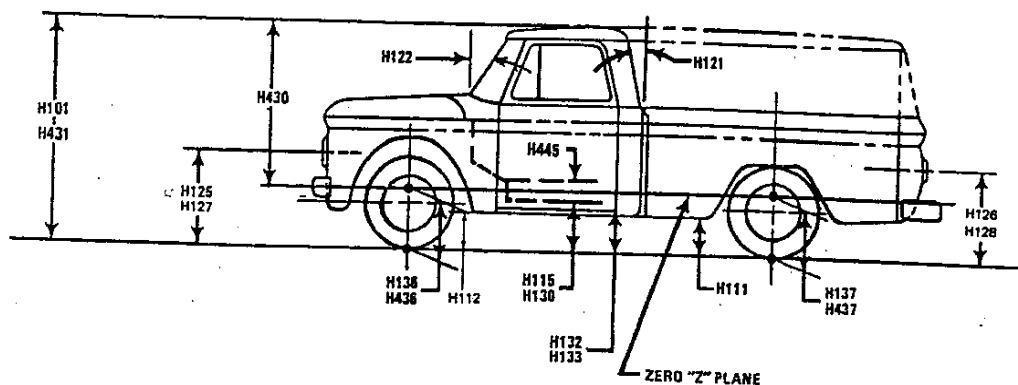

φFIG. 22—EXTERIOR DIMENSIONS, HEIGHT—TRUCK

dimension from the front of bumper to the foremost point of the cab, measured with the cab in the maximum servicing tilt position.

**L409**—Cab servicing tilt angle. The maximum angle of cab tilt for servicing, measured from a vertical line.

**L410**—Cab length. A longitudinal dimension from front of dash to back of cab at zero "Y" plane.

**L411**—Dual rear axle spacing. Horizontal dimension from centerline of forward rear axle to centerline of rearward rear axle at the zero "Y" plane.

φ **L419**—Distance from accelerator heel point (AHP) to centerline of occupant.

φ **L420**—Distance from AHP to intersection of front and top surface of hood.

φ **L421**—Maximum distance from AHP to intersection of front and top surface of hood.

**6.4 Ground Clearance Dimensions (See Fig. 26).**

**H102**—Front bumper to ground. The minimum dimension measured

vertically from the lowest point on the front bumper to ground, including bumper guards, if standard equipment.

**H103**—Front bumper to ground—curb weight. Measured in the same manner as H102.

**H104**—Rear bumper to ground. The minimum dimension measured vertically from the lowest point on the rear bumper to ground, including bumper guards, if standard equipment.

**H105**—Rear bumper to ground—curb weight. Measured in the same manner as H104.

**H106**—Angle of approach. The angle measured between a line tangent to the front tire static loaded radius arc and the initial point of structural interference forward of the front tire to ground. The limiting structural component shall be designated.

**H107**—Angle of departure. The angle measured between a line tangent to the rear tire static loaded radius arc and the initial point of structural interference rearward of the rear tire to ground. The limiting component shall be designated.

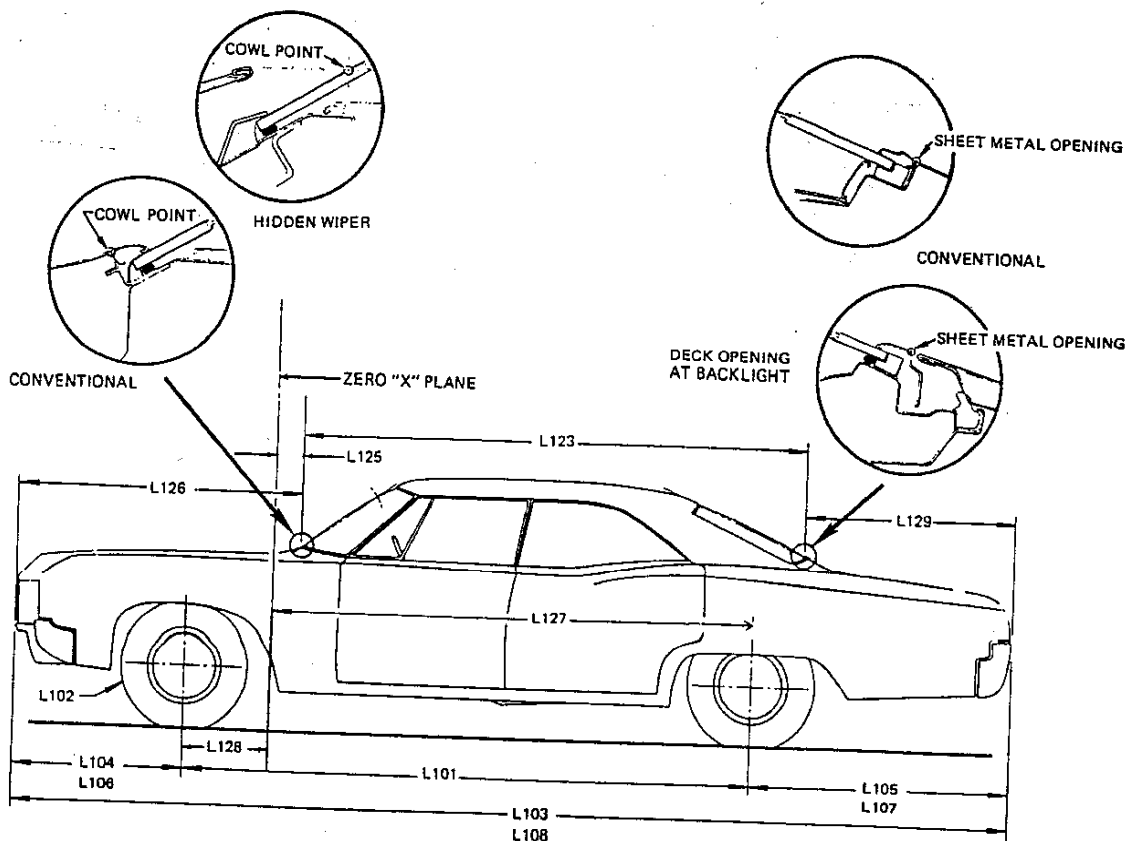

φFIG. 23—EXTERIOR DIMENSIONS, LENGTH

34.108

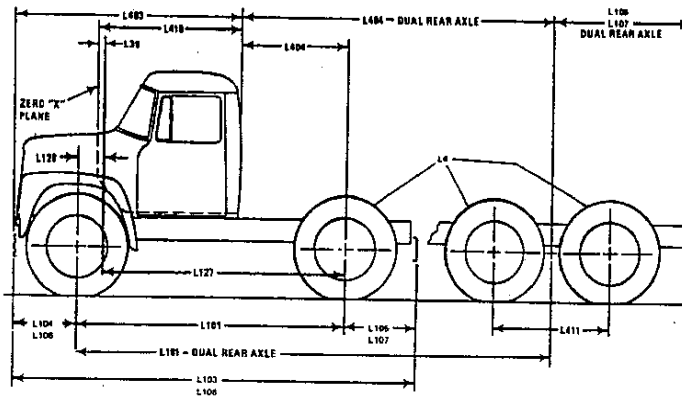

φFIG. 24—EXTERIOR DIMENSIONS, LENGTH—TRUCK

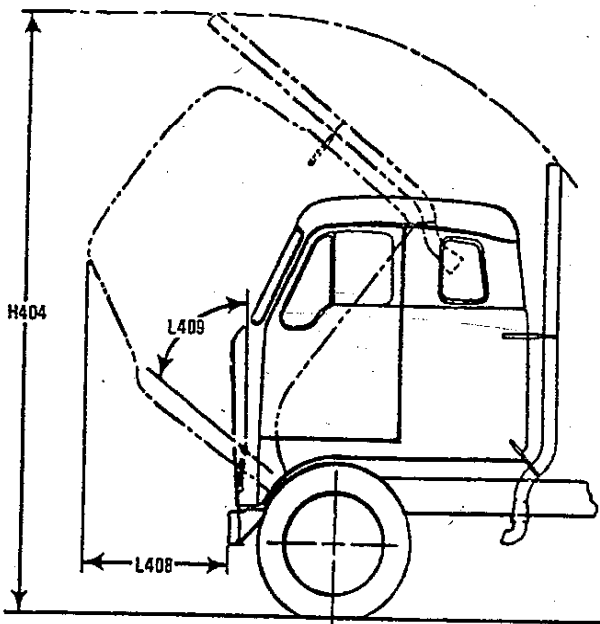

φFIG. 25—CAB SERVICING DIMENSIONS

H108—Static load—tire radius—front. Specified by the manufacturer in accordance with Composite Tire Section Standard.

H109—Static load—tire radius—rear. Specified by the manufacturer in accordance with Composite Tire Section Standard.

H147—Ramp breakover angle. The angle measured between two lines

tangent to the front and rear tire static loaded radius and intersecting at a point on the underside of the vehicle which defines the largest ramp over which the vehicle can roll.

H148—Front suspension to ground. The minimum dimension measured from the front suspension to ground. Specify component.

H149—Oil pan to ground. The minimum dimension measured from sheet metal or drain plug to ground.

H150—Flywheel/converter housing and transmission assembly to ground. The minimum dimension measured from flywheel/converter housing transfer case and/or transmission assembly to ground.

H151—Frame structure to ground. The minimum dimension measured approximately midway between front and rear axles including cross bars and x-members to ground.

H152—Exhaust system to ground. The minimum dimension measured from the exhaust system to ground. Specify location.

H153—Rear axle differential to ground. The minimum dimension measured from the rear axle differential to ground.

H154—Fuel tank to ground. The minimum dimension measured from sheet metal or drain plug, including supports or straps to ground.

H155—Spare tire well to ground. The minimum dimension measured from the spare tire well or spare tire including supports, to ground.

H156—Minimum running ground clearance. The minimum dimension measured from the sprung vehicle to ground. Specify location.

L102—Tire size. As specified by the manufacturer.

L4—Tire size—rear only if different than front. As specified by manufacturer.

7. Cargo Dimensions (See Figs. 27—31.)

H197—Front seatback to load floor height. The dimension measured vertically from the horizontal tangent to the top of the seatback to the undepressed floor covering.

H198—Second seatback to load floor height. The dimension measured vertically from the second seatback to the undepressed floor covering.

H201—Cargo height. The dimension measured vertically from the top of the undepressed floor covering to the headlining at the rear wheel "X" coordinate on the zero "Y" plane.

H202—Rear opening height. The dimension measured vertically from

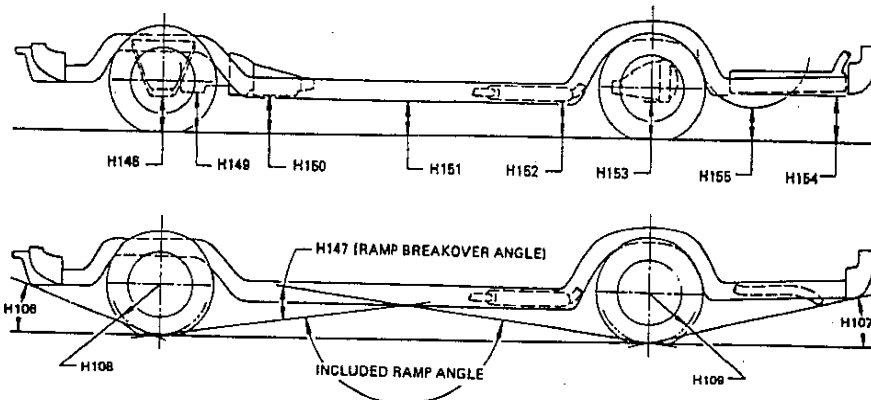

φFIG. 26—GROUND CLEARANCE DIMENSIONS

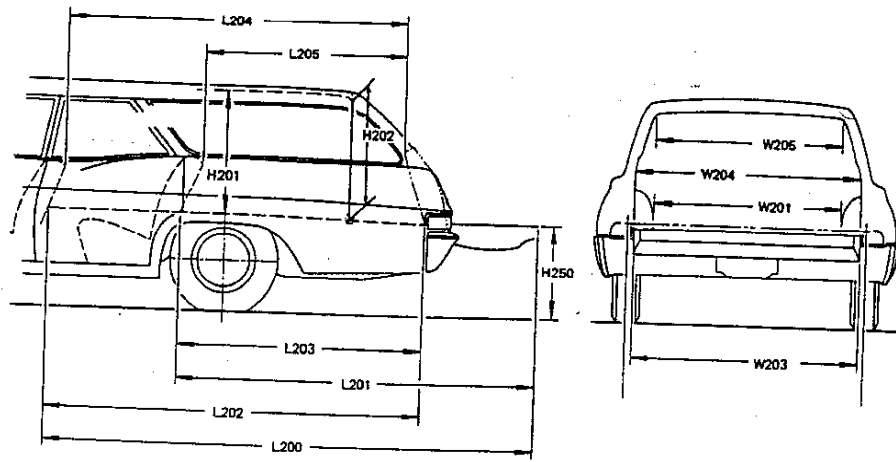

φFIG. 27—CARGO SPACE DIMENSIONS, STATION WAGON

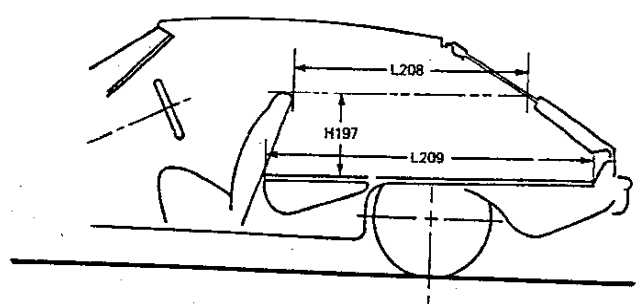

φFIG. 28—CARGO SPACE DIMENSIONS, HATCH BACK

from the cargo floor intersection with closed rear tailgate or cargo door to ground.

**H503**—Pickup body height. The minimum dimension measured vertically from the top of cargo floor to the top of the pickup body at the rear wheel "X" coordinate.

**H504**—Wheelhouse height. The maximum vertical dimension from top of cargo floor to the top of rear wheelhouse.

**H505**—Maximum cargo height. The maximum vertical dimension rear of the front seat from the cargo floor to roof bow or headlining at the zero "Y" plane.

**H506**—Cargo floor height. The "Z" coordinate of the top of cargo floor.

**H507**—Frame height. The "Z" coordinate of normal top of frame.

**H508**—Side cargo door opening height. The dimension measured vertically from the top of the undepressed floor covering or cargo floor to the upper side trimmed opening with side cargo doors open.

**L200**—Cargo length—open—front. The minimum dimension measured longitudinally from the back of the front seatback at the height of the undepressed floor covering to the rearmost point on the undepressed floor covering on the open tailgate or cargo surface, if the rear closure is a conventional door type tailgate, at the zero "Y" plane.

**L201**—Cargo length—open—second. The dimension measured longitudinally from the back of the second seatback at the height of the undepressed floor covering to the rearmost point on the undepressed floor

the top of the undepressed floor covering to the upper trimmed opening on the zero "Y" plane with rear door fully open.

**H250**—Tailgate to ground (curb weight). The dimension measured vertically from the top of the undepressed floor covering on the lowered tailgate to ground on the zero "Y" plane.

**H501**—Cargo floor height to ground. A vertical dimension from the cargo floor intersection with closed rear tailgate or cargo door to ground.

**H502**—Cargo floor height to ground (curb weight). A vertical dimension

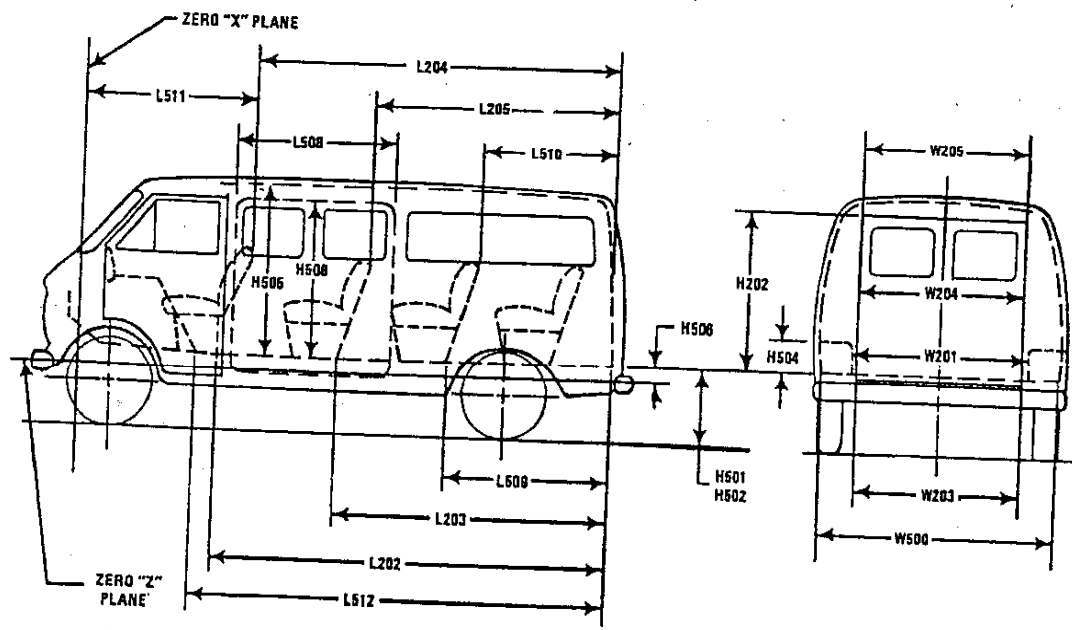

φFIG. 29—CARGO SPACE DIMENSIONS, TRUCK AND MPV WITH CLOSED CARGO AREA

34.110

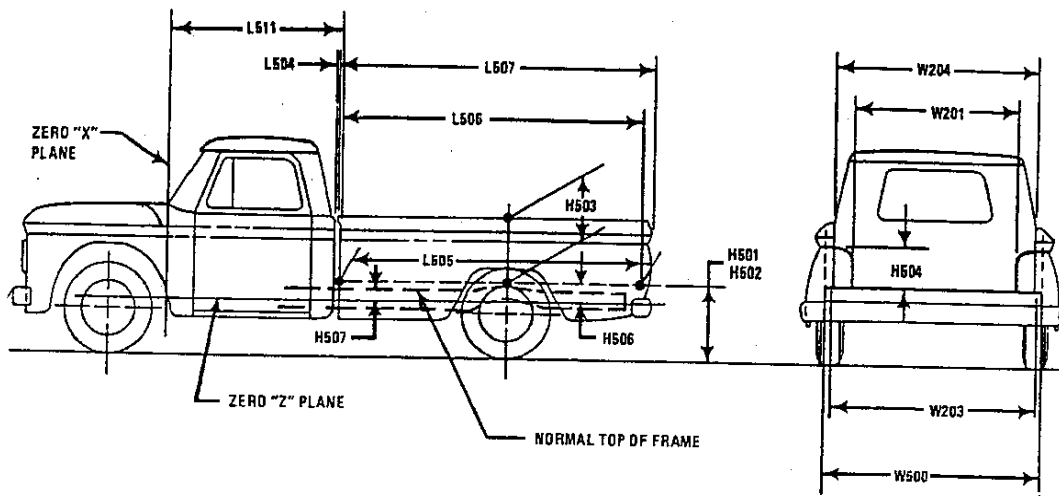

φFIG. 30—CARGO SPACE DIMENSIONS, TRUCK WITH OPEN CARGO AREA

covering on the open tailgate or cargo floor surface, if the rear closure is a conventional door type tailgate, at the zero "Y" plane.

**L202**—Cargo length—closed—front. The minimum dimension measured horizontally from the back of the front seat at the height of the undepressed floor covering to the rearmost point on the undepressed floor covering on the closed tailgate or taildoor for station wagons, trucks and MPV's at the zero "Y" plane.

**L203**—Cargo length—closed—second. The dimension measured horizontally from the back of the second seat at the height of the undepressed floor covering to the rearmost point on the undepressed floor covering on the closed tailgate or taildoor for station wagons, trucks and MPV's at the zero "Y" plane.

**L204**—Cargo length at belt—front. The minimum dimension measured horizontally from the back of the front seatback at the seatback top to the foremost normal surface of the closed tailgate or inside surface of the cab backpanel at the height of the belt, on the zero "Y" plane.

**L205**—Cargo length at belt—second. The minimum dimension measured horizontally from the back of the second seatback at the seatback top to the foremost normal surface of the closed tailgate at the height of the belt, on the zero "Y" plane.

**L208**—Cargo length at front seatback height—hatchback. The minimum horizontal dimension from the "X" plane tangent to the rearmost surface of the driver's seatback to the inside limiting interference of the hatchback door on the vehicle zero "Y" plane.

**L209**—Cargo length at floor—front—hatchback. The minimum horizontal dimension measured at floor level from the rear of the front seatback to the normal limiting interference of the hatchback door on the vehicle zero "Y" plane.

**L210**—Cargo length at second seatback height—hatchback. The minimum dimension measured from the "X" plane tangent to the rearmost surface of the second seatback or the load floor, which is stowed at least 1/4 the H198 dimension height above the rear load floor, to the rearmost inside limiting interference on the zero "Y" plane.

**L211**—Cargo length at floor—second—hatchback. The minimum horizontal dimension measured at floor level from the rear of the second seatback or load floor panel to the normal limiting interference of the hatchback door on the vehicle zero "Y" plane.

**L504**—Cab to pickup body. The horizontal dimension from rear of cab to the front of the pickup body, measured at the zero "Y" plane.

**L505**—Pickup body length at floor. The dimension measured longitudinally from inside the front of pickup body to the inside of the closed tailgate measured at floor level at the zero "Y" plane.

**L506**—Pickup body length at top of body. The dimension measured longitudinally from inside front of pickup body to the inside top of the closed tailgate measured at top of the pickup body at the zero "Y" plane.

**L507**—Cargo body overall length. A longitudinal dimension of the overall cargo body length at the zero "Y" plane.

**L508**—Side cargo door opening length. The minimum dimension measured longitudinally between the limiting interferences with side cargo doors in maximum hold-open position.

**L509**—Cargo length—closed—third. The minimum dimension measured horizontally from the back of the third seat (including seat support and restraint system) at the height of the undepressed floor covering to the rearmost point on the undepressed floor covering on the closed tailgate or taildoor at the zero "Y" plane. For vehicles with more than three seats, specify seat location along with dimension.

**L510**—Cargo length at belt—third. The minimum dimension measured horizontally from the back of the third seat back to the foremost normal surface of the closed tailgate or taildoor at the height of the belt, on zero "Y" plane. For vehicle with more than three seats, specify seat location along with dimension.

**L511**—Front cargo surface. The "X" coordinate of the front cargo surface. This surface is the rearmost point of driver's seat, on trucks with closed cargo area and is the front surface of the inside of cargo box on trucks with open cargo area.

**L512**—Cargo length to engine cover. The dimension measured longitudinally for the rear of the engine cover to the closed tailgate or taildoor at the zero "Y" plane. The dimension shall be at height of the cargo floor surface. If floor surface at engine cover is above cargo floor surface, then length is taken at floor to engine cover intersection height.

**W201**—Cargo width—wheelhouse. The minimum dimension measured laterally between the trimmed wheelhousings at floor level. For any vehicle not trimmed, measure the sheet metal.

**W203**—Rear opening width at floor. The minimum dimension mea-

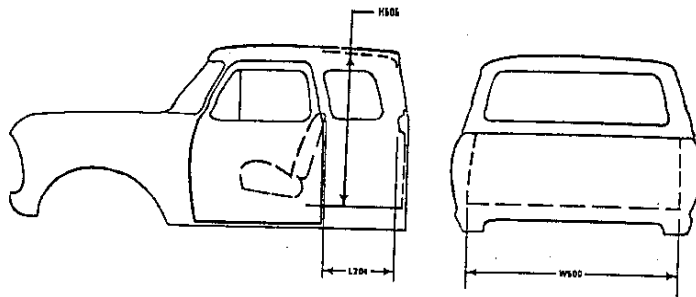

φFIG. 31—CARGO SPACE DIMENSIONS, TRUCK WITH CLOSED CARGO AREA

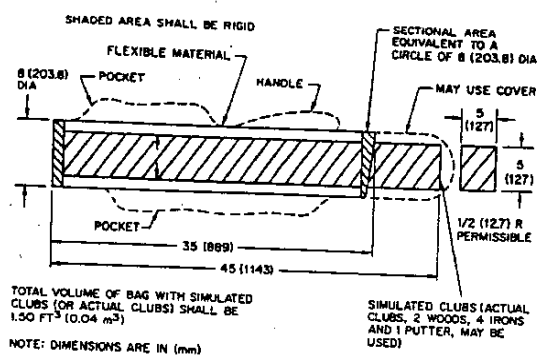

φFIG. 32—GOLF BAG

sured laterally between the limiting interferences of the rear opening at floor level.

**W204**—Rear opening width at belt. The minimum dimension measured laterally between the limiting interferences of the rear opening at belt height or top of pickup box.

**W205**—Rear opening width above belt. The minimum dimension measured laterally between the limiting interferences of the rear opening above the belt height.

**W500**—Cargo width at floor. The maximum dimension measured laterally between the limiting interferences at the floor level. This dimension shall include ribs and pillars, but will exclude wheelhouses.

**8. Luggage Capacity** (Passenger car excluding station wagons and hatchback)

**V1 Usable Luggage Capacity**—Total of volumes of individual pieces of standard luggage set plus H-boxes stowed in the luggage compartment in accordance with the procedure described in paragraph 8.2.

**8.1 Standard Luggage Set**—The standard luggage set consists of a set of replicas of luggage and golf bags with contents. A set of shoe-type boxes (H-boxes) are optionally used with the standard luggage set. Descriptions and sizes of the luggage pieces are detailed in Table 1. (see Fig. 32.)

**8.2 Procedure for Determining Usable Luggage Capacity**—Place, in random order, as many as one standard luggage set of luggage into the luggage compartment, excluding H-boxes. When the best load is obtained using the standard luggage set, H-boxes may be added to arrive at the final load. Pieces from subsequent standard luggage sets may be used when the previous set is placed in the luggage compartment. A piece from the standard luggage set may be removed to place an H-box in the compartment, provided the removed piece is replaced. The standard equipped spare tire and tools shall be properly installed in the luggage compartment. They may be loosened and moved to the limits of the attaching hardware and then retightened to attain the most advantageous position. Standard parts of the vehicle normally stored in the luggage compartment, such as a convertible top, shall be in the stored position when the usable luggage capacity is determined.

The luggage compartment lid or access door must close and lock freely without forcing or excessive slamming with all of the luggage in place in the compartment.

**9. Cargo Volume Index**  
**V2 Station wagon.**  
Measured in inches

$$\frac{W4 \times H201 \times L204}{1728} = \text{ft}^3$$

Measured in mm

$$\frac{W4 \times H201 \times L204}{10^9} = \text{m}^3 \text{ (cubic meter)}$$

**V3 Hatchback.**  
Measured in inches

$$\frac{\frac{L208 + L209}{2} \times W4 \times H197}{1728} = \text{ft}^3$$

Measured in mm

$$\frac{\frac{L208 + L209}{2} \times W4 \times H197}{10^9} = \text{m}^3 \text{ (cubic meter)}$$

**V4 Hidden Luggage Capacity—Rear of Front Seat.** The total volumes of individual pieces of one set of standard luggage stowed in any hidden cargo area below the load floor rear of the front seat.

**V5 Trucks and MPV's with open area.**  
Measured in inches

$$\frac{L506 \times W500 \times H503}{1728} = \text{ft}^3$$

Measured in mm

$$\frac{L506 \times W500 \times H503}{10^9} = \text{m}^3 \text{ (cubic meter)}$$

**V6 Trucks and MPV's with closed area.**  
Measured in inches

$$\frac{L204 \times W500 \times H505}{1728} = \text{ft}^3$$

Measured in mm

$$\frac{L204 \times W500 \times H505}{10^9} = \text{m}^3 \text{ (cubic meter)}$$

**V8 Hidden Luggage Capacity—Rear of Second Seat.** The total volumes of individual pieces of one set of standard luggage stowed in any hidden cargo area below the load floor rear of the second seat.

**V10 Station Wagon Cargo Volume Index.**  
Measured in inches

$$\frac{H201 \times L205 \times \frac{W4 + W201}{2}}{1728} = \text{ft}^3$$

Measured in mm

$$\frac{H201 \times L205 \times \frac{W4 + W201}{2}}{10^9} = \text{m}^3 \text{ (cubic meter)}$$

φTABLE 1—STANDARD LUGGAGE SET

Luggage (with Conventional Handles)	Box Size		Letter	No.	Volume/Piece	
	in	mm			ft <sup>3</sup>	m <sup>3</sup>
Men's 2-suit	9 × 19 × 24	229 × 483 × 610	A	4	2.375	0.067
Women's overnight	6.5 × 13 × 18	165 × 330 × 457	B	4	0.880	0.025
Women's pullman	9 × 16 × 26	229 × 406 × 660	C	2	2.167	0.061
Women's wardrobe	8.5 × 18 × 21	216 × 457 × 533	D	2	1.859	0.053
Women's train case	8 × 9 × 15	203 × 229 × 381	E	2	0.625	0.018
Men's overnight	7 × 14 × 21	178 × 356 × 533	F	2	1.191	0.034
Golf bag containing: 2 woods, 4 irons, 1 putter, 10-1/2 shoes, 3 golf balls	See Fig. 32		G	2	1.500	0.043
H-boxes	8 × 4.5 × 12.8	152 × 114 × 325	H	20	0.200	0.006
Total				38		

34.112

V11 Hatchback Cargo Volume Index—Usable luggage [one (1) standard luggage set] below floor.  
Measured in inches

$$\frac{L210 + L211}{2} \times W4 \times H198 = \text{ft}^3$$

Measured in mm

$$\frac{L210 + L211}{2} \times W4 \times H198 = \text{m}^3 \text{ (cubic meter)}$$

10. Glass Areas

- S1—Windshield area.
- S2—Side windows area. Includes the front door, rear door, vents, and rear quarter windows on both sides of the vehicle.
- S3—Backlight areas.
- S4—Total areas. Total of all areas (S1 + S2 + S3).

TABLE 2—DIMENSION INDEX—HEIGHT DIMENSIONS AND NUMERICAL SEQUENCE

Dimension and Location			Dimension and Location			Dimension and Location			Dimension and Location		
Ident.	Section No.	Fig. No.	Ident.	Section No.	Fig. No.	Ident.	Section No.	Fig. No.	Ident.	Section No.	Fig. No.
H5	5.1	3	H61	5.1	5	H105	6.4	20	H155	6.4	26
H6	5.5	8	H62	5.3		H106	6.4	26	H156	6.4	
H10	5.2	3	H63	5.2	5	H107	6.4	26	H158	6.2	21
H11	5.4	8	H64	5.5	8	H108	6.4	26	H159	6.2	21
H12	5.4	8	H65	5.1	6	H109	6.4	26	H160	6.2	21
H13	5.5	8	H66	5.2	6	H111	6.2	20, 22	H161	4.1	} Fig. 1 of SAE J182a
H14	5.5	8	H67	5.1	5	H112	6.2	20, 22	H162	4.2	
H17	5.5	8	H68	5.1	5	H114	6.1	20	H163	4.1	
H18	5.5	8	H69	5.4	7	H115	5.4	20, 22	H164	4.2	
H25	5.5	20	H70	5.1	7	H116	5.4	20	H167	4.3	
H26	5.1	2	H71	5.2	7	H121	5.5	20, 22	H168	4.3	
H27	5.1	2	H72	5.2	5	H122	5.5	20, 22	H195	6.2	21
H28	5.2	2	H73	5.2	5	H123	5.5	4	H196	6.2	21
H29	5.2	2	H74	5.4	6	H124	5.5	4	H197	7	28
H30	5.1	2	H75	5.1	7	H125	6.2	20, 22	H198	7	
H31	5.2	3	H76	5.2	7	H126	6.2	20, 22	H201	7	27
H32	5.4	3	H77	5.4	7	H127	6.2	20, 22	H202	7	27, 29
H33	5.4	3	H78	5.4	7	H128	6.2	20, 22	H250	7	27
H34	5.4	3	H79	5.1		H130	5.4	20, 22	H311	5.1	10
H35	5.1		H80	5.2		H131	5.4	20	H326	5.4	10
H36	5.2		H81	4.1	} Fig. 1 of SAE J182a	H132	6.2	21, 22	H350	5.2.1	15
H37	5.1	3	H82	4.2		H133	6.2	21, 22	H404	6.2	25
H38	5.2	3	H83	4.3		H134	6.2	21	H430	6.2	22
H39	5.3		H84	5.3		H135	6.2	21	H431	6.2	22
H40	5.4	8	H85	5.3	16	H136	6.2	21, 22	H436	6.2	22
H45	5.1		H86	5.3	16	H137	6.2	21, 22	H437	6.2	22
H49	5.5	4	H87	5.3	16	H138	6.2	20	H445	5.4	22
H50	5.4	4	H88	5.3	16	H139	6.2	21	H446	5.4	
H51	5.4	4	H89	5.3	16	H140	6.2	21	H501	7	29, 30
H53	5.1	4	H90	5.3		H147	6.4	26	H502	7	29, 30
H54	5.1	6	H91	5.1	9	H148	6.4	26	H503	7	30
H55	5.2	4	H92	5.4		H149	6.4	26	H504	7	29, 30
H56	5.1	6	H94	5.4	6	H150	6.4	26	H505	7	29, 31
H57	5.2	6	H101	6.2	20, 22	H151	6.4	26	H506	7	29, 30
H58	5.1	5	H102	6.4	20	H152	6.4	26	H507	7	30
H59	5.1	9	H103	6.4	20	H153	6.4	26	H508	7	29
H60	5.2	4	H104	6.4	20	H154	6.4	26			

TABLE 3—GLASS AREA DIMENSIONS

Ident.	Section No.	Fig. No.
S1	10	—
S2	10	—
S3	10	—
S4	10	—

TABLE 5—PASSENGER DISTRIBUTION DIMENSIONS

Ident.	Section No.	Fig. No.
PD1		—
PD2	5.1	—
PD3	5.2	—
	5.3	—

TABLE 4—LUGGAGE AND CARGO VOLUME INDEX DIMENSIONS

Ident.	Section No.	Fig. No.
V1	8.1	—
V2	9	—
V3	9	—
V4	9	—
V5	9	—
V6	9	—
V8	9	—
V10	9	—
V11	11	—

TABLE 6—SEAT FACING DIRECTION DIMENSION

Ident.	Section No.	Fig. No.
SD1	5.3	—



φ TABLE 7—DIMENSION INDEX—LENGTH DIMENSIONS AND NUMERICAL SEQUENCE

Dimension and Location			Dimension and Location			Dimension and Location			Dimension and Location		
Ident.	Section No.	Fig. No.	Ident.	Section No.	Fig. No.	Ident.	Section No.	Fig. No.	Ident.	Section No.	Fig. No.
L3	5.2	11	L38	5.1		L92	5.3		L308	5.1	10
L4	6.3	24	L39	5.2		L101	6.3	23, 24	L324	5.5	
L7	5.5	11	L40	5.1	13	L102	6.3	23	L330	5.5	17
L9	5.4	11	L41	5.2	13	L103	6.3	23, 24	L331	5.5	17
L10	5.4	11	L42	5.1	13	L104	6.3	23, 24	L332	5.5	17
L11	5.5	12	L43	5.2	13	L105	6.3	23, 24	L350	5.2.1	15
L12	5.4	11	L44	5.1	13	L106	6.3	23, 24	L403	6.3	24
L13	5.5	11	L45	5.2	13	L107	6.3	23, 24	L404	6.3	24
L14	5.4	11	L46	5.1	13	L108	6.3	23, 24	L408	6.3	25
L15	5.4	11	L47	5.2	13	L114	5.1	11	L409	6.3	25
L16	5.4	11	L48	5.2	12	L123	6.3	23	L410	6.3	24
L17	5.1	9	L50	5.2	12	L125	6.3	23	L411	6.3	24
L18	5.4	14	L51	5.2	12	L126	6.3	23	L419	6.3	24
L19	5.4	14	L52	5.5	12	L127	6.3	23, 24	L420	6.3	17
L20	5.4		L53	5.1	12	L128	6.3	23, 24	L421	6.3	17
L21	5.4		L54	4.1	Fig. 1 of SAE J182a	L129	6.3	23	L504	7	17
L22	5.4	7	L55	4.2		L200	7	27	L505	7	30
L23	5.1	9	L56	4.3		L201	7	27	L506	7	30
L24	5.4		L62	5.1		L202	7	27, 29	L507	7	30
L30	6.3	11, 24	L85	5.3	16	L203	7	27, 29	L508	7	30
L31	5.1	11	L86	5.3	16	L204	7	27, 29, 31	L509	7	29
L32	5.2	11	L87	5.3	16	L205	7	27, 29	L510	7	29
L34	5.1	12	L88	5.3	16	L208	7	28	L511	7	29
L35	5.2	11	L89	5.3	16	L209	7	28	L512	7	29, 30
L36	5.3		L90	5.3	16	L210	7				29
L37	5.1	9	L91	5.3	16	L211	7				

φ TABLE 8—DIMENSION INDEX WIDTH DIMENSIONS AND NUMERICAL SEQUENCE

Dimension and Location			Dimension and Location			Dimension and Location			Dimension and Location		
Ident.	Section No.	Fig. No.	Ident.	Section No.	Fig. No.	Ident.	Section No.	Fig. No.	Ident.	Section No.	Fig. No.
W3	5.1	14	W24	5.1		W85	5.3	16	W122	5.5	18
W4	5.2	14	W25	5.2	14	W86	5.3	16	W201	7	27, 29, 30
W5	5.1	14	W26	5.3		W101	6.1	18	W203	7	27, 29, 30
W6	5.2	14	W30	5.5		W102	6.1	18, 19	W204	7	27, 29, 30
W7	5.5	14	W32	5.1		W103	6.1	18	W205	7	27, 29
W9	5.5	14	W33	5.2		W106	6.1	18	W300	5.1	10
W16	5.4	14	W34	5.3		W107	6.1	18	W301	5.1	10
W20	5.1	14	W38	5.1		W116	6.1	18	W306	5.2.1	13
W21	4.1	Fig. 1 of SAE J182a	W39	5.2		W117	6.1	18	W409	6.1	19
W22	4.2		W40	5.3		W120	6.1	18	W410	6.1	19
W23	4.3		W41	5.5	18	W121	6.1	18, 19	W500	7	29, 30, 31

34.114

TABLE 9—DIMENSION INDEX—ALPHABETICAL SEQUENCE

Definition	Dim. Ident.	Section No.	Fig. No.	Definition	Dim. Ident.	Section No.	Fig. No.
Accelerator Pedal to Steering Wheel Clearance	L332	5.5	17	Effective Leg Room—Third	L86	5.3	16
AHP to Centerline of Occupant	L419	6.3	17	Effective T-Point Head Room—Front	H75	5.1	7
AHP to Intersection of Front and Top Surface of Hood	L420	6.3	17	Effective T-Point Head Room—Second	H76	5.2	7
AHP to Intersection of Front and Top Surface of Hood—max distance	L421	6.3	17	Effective T-Point Head Room—Third	H89	5.3	16
Accelerator Heel Point To Steering Wheel Center	L11	5.5	12	Engine Cover Height	H311	5.1	10
Accelerator Heel Point To Steering Wheel Center	H17	5.5	8	Engine Cover Length	L308	5.1	10
Angle of Approach	H106	6.3	26	Entrance Foot Clearance—Front	L18	5.4	14
Angle of Departure	H107	6.3	26	Entrance Foot Clearance—Second	L19	5.4	14
Back Angle—Front	L40	5.1	13	Entrance Height—Front	H11	5.4	8
Back Angle—Second	L41	5.2	13	Entrance Height—Second	H12	5.4	8
Back Angle—Third	L88	5.3	16	Exhaust System to Ground	H152	6.4	26
Backlight Area	S3	10		Exit Height—Second	H69	5.4	7
Backlight Slope Angle	H121	5.5	20, 22	Eyellipse to Backlight Upper Opening	H123	5.5	4
Belt Height—Front	H25	5.5	20	Eyellipse to Bottom of Inside Rear View Mirror	H14	5.5	8
Body Height	H430	6.2	22	Eyellipse to Top of Steering Wheel	H49	5.5	4
Body Thickness	H160	6.2	21	Fiducial Mark Number 1			
Body Width at SgRP—Front	W117	6.1	18	X Coordinate	L54	4.1	
Body Width—Maximum	W116	6.1	18	Y Coordinate	W21	4.1	
Bottom of Door Ajar—Front to Ground	H139	6.2	21	Z Coordinate	H81	4.1	
Bottom of Door Ajar—Rear to Ground	H140	6.2	21	Height—Z Coordinate to Ground	H163	4.1	
Bottom of Door—Closed—Front to Ground	H133	6.2	21, 22	Height—Z Coordinate to Ground at Curb			
Bottom of Door—Closed—Rear to Ground	H135	6.2	21	Weight	H161	4.1	
Bottom of Door—Open—Front to Ground	H132	6.2	21, 22	Fiducial Mark Number 2			
Bottom of Door—Open—Rear to Ground	H134	6.2	21	X Coordinate	L55	4.2	
Brake Pedal Knee Clearance	L13	5.5	11	Y Coordinate	W22	4.2	
Brake Pedal to Accelerator	L52	5.5	12	Z Coordinate	H82	4.2	
Brake Pedal to Steering Wheel Clearance	L331	5.5	17	Height—Z Coordinate to Ground	H164	4.2	
Cab Length	L410	6.3	24	Height—Z Coordinate to Ground at Curb			
Cab Servicing Tilt Angle	L409	6.3	25	Weight	H162	4.2	
Cab to Pickup Body	L504	7	30	Fiducial Mark Number 3			
Cab to Rear Axle	L404	6.3	24	X Coordinate	L56	4.3	
Cargo Body Overall Length	L507	7	30	Y Coordinate	W23	4.3	
Cargo Floor Height	H506	7	29, 30	Z Coordinate	H83	4.3	
Cargo Floor Height to Ground	H501	7	29, 30	Height—Z Coordinate to Ground	H168	4.3	
Cargo Floor Height to Ground—(Curb Weight)	H502	7	29, 30	Height—Z Coordinate to Ground at Curb			
Cargo Height	H201	7	27	Weight	H167	4.3	
Cargo Length at Belt—Front	L204	7	27, 29, 31	Floor Covering Depressed—Second	H73	5.2	
Cargo Length at Belt—Second	L205	7	27, 29	Floor Covering Thickness Depressed—Front	H68	5.1	5
Cargo Length at Belt—Third	L510	7	29	Floor Covering Thickness Undepressed—Front	H67	5.1	5
Cargo Length at Floor—Front Hatchback	L209	7	28	Floor Covering Thickness Undepressed—Second	H72	5.2	5
Cargo Length at Front Seatback Height—Hatchback	L208	7	28	Flywheel/Converter Housing and Transmission Assembly to Ground	H150	6.4	26
Cargo Length—Closed—Front	L202	7	27, 29	Foot Angle—Front	L46	5.1	13
Cargo Length—Closed—Second	L203	7	27, 29	Foot Angle—Second	L47	5.2	13
Cargo Length—Closed—Third	L509	7	29	Foot Angle—Third	L91	5.3	16
Cargo Length—Open—Front	L200	7	27	Frame Height	H507	7	30
Cargo Length—Open—Second	L201	7	27	Frame Structure to Ground	H151	6.4	26
Cargo Length to Engine Cover	L512	7	29	Front Bumper to Cab—Tilt Cab Servicing Position			
Cargo Volume Index (Hatchback)	V3	9		Front Bumper to Ground	L408	6.3	25
Cargo Volume Index (Station Wagon)	V2	9		Front Bumper to Ground—Curb Weight	H102	6.4	20
Cargo Width at Floor	W500	7	29, 30, 31	Front Cargo Surface	H103	6.4	20
Cargo Width—Wheelhouse	W201	7	27, 29, 30	Front End Length	L511	7	29, 30
Clutch Pedal to Steering Wheel Clearance	L330	5.5	17	Front Fender Width	L126	6.3	23
Compartment Room—Second	L3	5.2	11	Front Fender Width	W106	6.1	18
Compartment Room—Third	L92	5.3		Front of Bumper to Back of Cab	L403	6.3	24
Cowl Point to Ground	H114	6.1	20	Front of Dash—"X" Coordinate	L30	6.3	11, 24
Cowl Point—X Coordinate	L125	6.3	23	Front Seatback to Load Floor Height	H197	7	28
Cushion Deflection—Front	H32	5.4	3	Front Suspension to Ground	H148	6.4	26
Cushion Deflection—Second	H33	5.4	3	Front Wheel C/L to Front SgRP	L114	5.1	11
Cushion Deflection—Third	H34	5.4	3	Front Wheel C/L X Coordinate	L128	6.3	23, 24
Cushion Depth—Front	L9	5.4	11	Fuel Tank to Ground	H154	6.4	26
Cushion Depth—Second	L16	5.4	11	Head Clearance—Minimum—Second	W39	5.2	
Cushion Depth—Third	L21	5.4	11	Head Clearance—Minimum—Third	W40	5.3	
Cushion Width—Front	W16	5.4	14	Head Clearance to Back Window Garnish	L39	5.2	
Deck Point to Ground	H138	6.2	20	Head Clearance to Headlining—Second	H36	5.2	
Design H-Point Front Travel	L17	5.1	9	Head Clearance to Headlining—Third	H39	5.3	
Design H-Point Rise	H58	5.1	5, 9	Head Clearance to Roof Rail Garnish—Second	W33	5.2	
Design H-Point Travel	H45	5.1		Head Clearance to Roof Rail Garnish—Third	W34	5.3	
D Point—Center Pass.—Second—to Tunnel	H55	5.2	4	Headlamp to Ground	H125	6.2	20, 22
D Point—Front Differential—Side to Center	H65	5.1	6	Headlamp to Ground—Curb Weight	H127	6.2	20, 22
D Point—Front to Floor	H56	5.1	6	Headlining to Roof Panel—Front	H37	5.1	3
D Point—Front to Heel	H53	5.1	4	Headlining to Roof Panel—Second	H38	5.2	3
D Point—Front to Tunnel Center Passenger	H54	5.1	6	Headlining to Roof—Third	H84	5.3	
D Point—Differential—Side to Center—Second	H66	5.2	6	Hidden Cargo Volume	V4	9	
D Point—Second to Floor	H57	5.1	6	Hip Angle—Front	L42	5.1	13
D Point—Third—to Floor	H90	5.3	6	Hip Angle—Second	L43	5.2	13
D Point to Heel Point—Second	H60	5.2	4	Hip Angle—Third	L89	5.3	16
D Point to Heel Point—Third	H62	5.3	4	Hip Room—Front	W5	5.1	14
Dual Rear Axle Spacing	L411	6.3	24	Hip Room—Second	W6	5.2	14
Driver Head Clearance—Minimum	W38	5.1		Hip Room—Third	W86	5.3	16
Driver Head Clearance to Headlining	H35	5.1		Interior Body Height—Front or SgRP Y Plane	H27	5.1	2
Driver Head Clearance to Roof Rail Garnish	W32	5.1		Interior Body Height—Front or Zero Y Plane	H26	5.1	2
Driver Head Clearance to Windshield Garnish	L38	5.1		Interior Body Height—Second—at SgRP Y Plane			
Effective Cushion Depth—Front	L10	5.4	11	Interior Body Height—Second—at Zero Y Plane	H29	5.2	2
Effective Cushion Depth—Second	L12	5.4	11	Knee Angle—Front	L44	5.1	13
Effective Cushion Depth—Third	L24	5.4	11	Knee Angle—Second	L45	5.2	13
Effective Head Room—Front	H61	5.1	5	Knee Angle—Third	L90	5.3	16
Effective Head Room—Second	H63	5.2	5	Knee Clearance—Front	L62	5.1	
Effective Head Room—Third	H86	5.3	16	Knee Clearance—Second	L48	5.2	12
				Knee Clearance—Third	L87	5.3	16
				Liftover Height	H195	6.2	21

Fig. 1 of SAE J182a

φ DEFINITIONS (continued)

Definition	Dim. Ident.	Section No.	Fig. No.	Definition	Dim. Ident.	Section No.	Fig. No.
Liftover Height—Curb Weight	H196	6.2	21	SgRP—Second—Z Coordinate	H71	5.2	7
Maximum Cargo Height	H505	7	29, 31	SgRP—Third to Ground	H85	5.3	16
Maximum Effective Leg Room—Accelerator	L34	5.1	12	SgRP—Third to Heel Point	H87	5.3	16
Maximum Overall Height—Tilt Cab Servicing	H404	6.2	25	SgRP—Third—X Coordinate	L36	5.3	
Minimum Effective Leg Room—Second	L51	5.2	12	SgRP—Third—Y Coordinate	W26	5.3	
Minimum Running Ground Clearance	H156	6.4		SgRP—Third—Z Coordinate	H88	5.3	16
Normal Driving and Riding Design H Point Rise	H59	5.1	9	SgRP to Windshield Upper DLO	L324	5.5	
Normal Driving and Riding Seat Track Travel	L23	5.1	9	Shoulder Room—Front	W3	5.1	14
Oil Pan to Ground	H149	6.4	22	Shoulder Room—Second	W4	5.2	14
Outside Mirror Width	W410	6.1	19	Shoulder Room—Third	W85	5.3	16
Overhang—Front	L104	6.3	23, 24	Side Cargo Door Opening Height	H508	7	29
Overhang—Front—RPO	L106	6.3	23, 24	Side Cargo Door Opening Length	L508	7	29
Overhang—Rear	L105	6.3	23, 24	Side Glass Height	H159	6.2	21
Overhang—Rear—RPO	L107	6.3	23, 24	Side Glass Radius	W41	5.5	18
Passenger Distribution—Front	PD1	5.1		Side Window Area	S2	10	
Passenger Distribution—Second	PD2	5.2		Sleeper Compartment Height	H350	5.2.1	15
Passenger Distribution—Third	PD3	5.3		Sleeper Compartment Length	L350	5.2.1	15
Pick-Up Body Height	H503	7	30	Sleeper Compartment Width	W306	5.2.1	15
Pick-Up Body Length at Floor	L505	7	30	Spare Tire Well to Ground	H155	6.3	26
Pick-Up Body Length At Top of Body	L506	7	30	Static Load—Tire Radius—Front	H108	6.3	26
Ramp Breakover Angle	H147	6.4	26	Static Load—Tire Radius—Rear	H109	6.3	26
Rear Axle Differential to Ground	H153	6.4	26	Steering Wheel Angle	H18	5.5	8
Rear Bumper to Ground	H104	6.4	20	Steering Wheel Center—Y Coordinate	W7	5.5	14
Rear Bumper to Ground—Curb Weight	H105	6.4	20	Steering Wheel Maximum Outside Diameter	W9	5.5	14
Rear End Length	L129	6.3	23	Steering Wheel to Accelerator Heel Point	H40	5.4	8
Rear Fender Width	W107	6.1	18	Steering Wheel to C/L Thigh	H13	5.5	8
Rearmost Design H Point—Front				Steering Wheel to Cushion	H74	5.4	6
X Coordinate	L37	5.1	9	Steering Wheel to Door Clearance	H94	5.4	6
Y Coordinate	W24	5.1		Steering Wheel to Seatback	W30	5.5	
Z Coordinate	H91	5.1	9	Steering Wheel Torso Clearance	L22	5.4	7
Rear Opening Height	H202	7	27, 29	Step Height—Front	L7	5.5	11
Rear Opening Width Above Belt	W205	7	27, 29	Step Height—Front—Curb Weight	H115	5.4	20, 22
Rear Opening Width at Belt	W204	7	27, 29, 30	Step Height—Second	H130	5.4	20, 22
Rear Opening Width at Floor	W203	7	27, 29, 30	Step Height—Second—Curb Weight	H116	5.4	20
Rear Wheel C/L X Coordinate	L127	6.3	23, 24	Tailgate to Ground	H131	5.4	20
Rocker Panel—Front—to Ground	H112	6.2	20, 22	Tail Lamp to Ground	H250	7	27
Rocker Panel—Rear—to Ground	H111	6.2	20, 22	Tail Lamp to Ground—Curb Weight	H126	6.2	20, 22
Roof Thickness	H158	6.2	21	Tire Size	H128	6.2	20, 22
Seatback Height—Front	H77	5.4	7	Tire Size—Rear	L102	6.3	23
Seatback Height—Second	H78	5.4	7	Total Area	L4	6.3	24
Seatback Height—Third	H92	5.4		Tread—Front	S4	10	
Seatback Thickness—Front	L14	5.4	11	Tread—Rear	W101	6.1	18
Seatback Thickness—Second	L15	5.4	11	Tumble Home	W102	6.1	18, 19
Seatback Thickness—Third	L20	5.4		Upper Body Opening to Ground—Front	W122	5.5	18
Seat Cushion Height—Front	H326	5.4	10	Upper Body Opening to Ground—Second	H50	5.4	4
Seat Facing Direction—Third	SD1	5.3		Upper Structure Length	H51	5.4	4
Second Step Height—Front	H445	5.4	22	Usable Luggage Capacity	L123	6.3	23
Second Step Height—Second	H446	5.4		Vehicle Height	V1	8.1	
SgRP Couple Distance—Second	L50	5.4	12	Vehicle Height—Curb Weight	H101	6.2	20, 22
SgRP Couple Distance—Third	L85	5.3	16	Vehicle Length	H431	6.2	22
SgRP Differential—Side to Center	H79	5.1		Vehicle Length—RPO	L103	6.3	23, 24
SgRP Front to Ground	H80	5.2		Vehicle Width	L108	6.3	23, 24
SgRP Front to Heel	H5	5.1	3	Vehicle Width—Front Doors Open	W103	6.1	18
SgRP Front to Heel	L53	5.1	12	Vehicle Width—Rear Doors Open	W120	6.1	18
SgRP Front to Windshield Lower DLO	H30	5.1	2	Vehicle Width—Tail Doors Open	W121	6.1	18, 19
SgRP Front to Windshield Upper DLO	H5	5.5	8	Vision Angle to Windshield Upper DLO	W409	6.1	19
SgRP—Front—X Coordinate	H64	5.5	8	Wheelbase	H124	5.5	4
SgRP—Front—Y Coordinate	L31	5.1	11	Wheelhouse Height	L101	6.3	23, 24
SgRP—Front—Z Coordinate	W20	5.1	14	Windshield Area	H504	7	29, 30
SgRP—Second to Ground	H70	5.1	7	Windshield Slope Angle	S1	10	
SgRP—Second to Heel	H10	5.2	3	Zero Z Plane to Ground—Front	H122	5.5	20, 22
SgRP—Second to Rear Wheel C/L	H31	5.2	3	Zero Z Plane to Ground—Front—Curb Weight	H136	6.2	21, 22
SgRP—Second—X Coordinate	L32	5.2	11	Zero Z Plane to Ground—Rear	H436	6.2	22
SgRP—Second—Y Coordinate	L35	5.2	11	Zero Z Plane to Ground—Rear—Curb Weight	H137	6.2	21, 22
	W25	5.2	14		H437	6.2	22